



This is a digital copy of a book that was preserved for generations on library shelves before it was carefully scanned by Google as part of a project to make the world's books discoverable online.

It has survived long enough for the copyright to expire and the book to enter the public domain. A public domain book is one that was never subject to copyright or whose legal copyright term has expired. Whether a book is in the public domain may vary country to country. Public domain books are our gateways to the past, representing a wealth of history, culture and knowledge that's often difficult to discover.

Marks, notations and other marginalia present in the original volume will appear in this file - a reminder of this book's long journey from the publisher to a library and finally to you.

Usage guidelines

Google is proud to partner with libraries to digitize public domain materials and make them widely accessible. Public domain books belong to the public and we are merely their custodians. Nevertheless, this work is expensive, so in order to keep providing this resource, we have taken steps to prevent abuse by commercial parties, including placing technical restrictions on automated querying.

We also ask that you:

- + *Make non-commercial use of the files* We designed Google Book Search for use by individuals, and we request that you use these files for personal, non-commercial purposes.
- + *Refrain from automated querying* Do not send automated queries of any sort to Google's system: If you are conducting research on machine translation, optical character recognition or other areas where access to a large amount of text is helpful, please contact us. We encourage the use of public domain materials for these purposes and may be able to help.
- + *Maintain attribution* The Google "watermark" you see on each file is essential for informing people about this project and helping them find additional materials through Google Book Search. Please do not remove it.
- + *Keep it legal* Whatever your use, remember that you are responsible for ensuring that what you are doing is legal. Do not assume that just because we believe a book is in the public domain for users in the United States, that the work is also in the public domain for users in other countries. Whether a book is still in copyright varies from country to country, and we can't offer guidance on whether any specific use of any specific book is allowed. Please do not assume that a book's appearance in Google Book Search means it can be used in any manner anywhere in the world. Copyright infringement liability can be quite severe.

About Google Book Search

Google's mission is to organize the world's information and to make it universally accessible and useful. Google Book Search helps readers discover the world's books while helping authors and publishers reach new audiences. You can search through the full text of this book on the web at <http://books.google.com/>

UC-NRLF



\$B 32 961

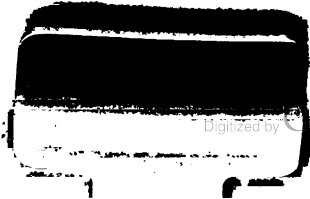
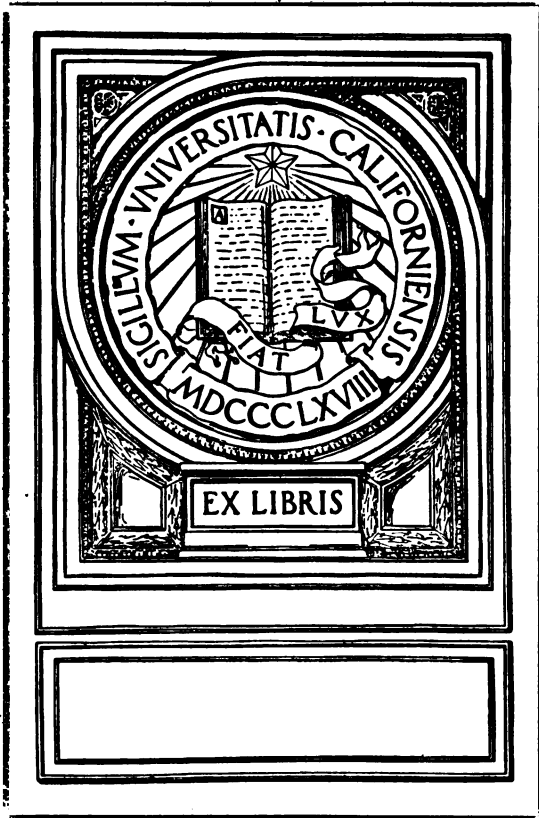

CROSBY LOCKWOOD & SON'S

LIST OF WORKS

ON

TRADES AND MANUFACTURES, THE INDUSTRIAL ARTS, CHEMICAL MANUFACTURES, COUNTING HOUSE WORK, Etc.

A Complete Catalogue of NEW and STANDARD BOOKS relating to CIVIL, MECHANICAL, MARINE and ELECTRICAL ENGINEERING; MINING, METALLURGY, and COLLIERY WORKING; ARCHITECTURE and BUILDING; AGRICULTURE and ESTATE MANAGEMENT, &c. Post Free on Application.

LONDON:
7, STATIONERS' HALL COURT, LUDGATE HILL, E.C.,
AND
5, Broadway, Westminster, S.W.

1915.

Messrs. CROSBY LOCKWOOD & SON beg to announce that they have been appointed Agents for the sale of the series of "BOOKS FOR HOME STUDY," issued under the American School of Correspondence, Chicago. These books are both practical and scientific, written by experts whose experience and standing make them authorities on the subjects which they treat. A full descriptive list will be sent post free on application.



TWO-BLADED AIR-SCREW DESIGNED BY THE AUTHOR FOR 60 HP. LE RHÔNE AEROPLANE ENGINE.

Translational Velocity of Aeroplane	77.6 feet per second.
Rotational Speed of Engine	1200 revolutions per minute.
Calculated Efficiency of Air-Screw	71.6 per cent.

AIR-SCREWS

*An Introduction to the Aerofoil Theory of
Screw Propulsion*

BY

M. A. S. RIACH

ASSOCIATE FELLOW OF THE AERONAUTICAL SOCIETY

“In mediis quæ rigore omni vacant resistantiæ corporum
sunt in duplicata ratione velocitatum.”—*Newton*.



NEW YORK
D. APPLETON AND COMPANY
MCMXVI

TL705
R4

PRINTED IN GREAT BRITAIN



PREFACE

WITH the coming of the Aeroplane the quantitative study of screws working in air has assumed a great importance.

Formerly in the design of screw propellers for marine work experiments with models were carried out and the performance of the full size screw calculated from them, and it was not until 1882 that Drzewiecki first drew attention to a possible more powerful method of design obtained by considering each element along the blade as independent and behaving in the same manner as if moving through the fluid in a straight line.

This method has since assumed great importance in the practical design of air-screw blades, and the results obtained seemed to justify the utilization of this theory as at least approximately correct provided certain limits are not exceeded.

In the present work the theory has been assumed to be absolutely correct, and the results obtained have been carried to their logical conclusions. This has been done for various reasons.

It does not make for completeness in any argument if the results of the initial hypothesis are not carried to their ultimate logical conclusions, and although in the present instance the results so obtained may not be completely borne out in practice, yet, in giving an insight into the applications of the theory, and in establishing at any rate an approximate method for dealing with the many cases arising out of the performances of aircraft, the conclusions arrived at will, it is hoped, not be without interest.

In any case the practical application of some of the more extreme results should not be made without due caution, and

358026

in fact they are to be regarded as of an extremely tentative nature. This caution is necessary, for "There is no more common error than to assume that, because prolonged and accurate mathematical calculations have been made, the application of the result to some fact of nature is absolutely certain. The conclusion of no argument can be more certain than the assumption from which it starts" (Whitehead, "Introduction to Mathematics"). Mathematics are too often apt to be regarded as capable of "creating" results, quite independently of any initial hypotheses, when they are nothing more than a very useful tool.

I have endeavoured to present the subject of air-screw design in as simple a manner as possible, so that the ordinary non-mathematical reader may be able to follow the train of reasoning, at any rate as far as its qualitative nature is concerned.

It may be that the first chapter is unnecessarily drawn out, but it appears to me that in any investigation of this kind the first essential is to be able to clearly "visualise" what is being done, the mere application of analytical processes being but a secondary matter.

I have introduced graphical methods wherever it seemed to be necessary, or where it was impossible to obtain solutions without them. At the same time the results for the design of an air-screw to fulfil any specified outside conditions have been put into such a form that it is hoped that the design will be able to be correctly carried out by the rules given, even if the analytical processes have not been able to be followed by the reader.

With regard to the possible errors involved in the application of the results given in the text, these should not be found to materially affect any but the last chapters of the book. The chapters on "static" thrust, efficiency of air-screws from (V) equal to zero up to the velocity of flight, and on direct lifting systems, are admittedly of a speculative character.

It did not seem that a work of this kind could be regarded as complete without some reference to the stresses occurring in an air-screw blade, and accordingly a chapter on centrifugal and bending stresses has been included.

It is hoped that the book will be found to be not without interest to engineers desiring an introduction to the theory of air-screws, while at the same time it may perhaps conduce to a more scientific study of the subject, in place of what has been aptly described as the "make it 4 by 2" methods so dear to the heart of the "practical" man.

I take this opportunity of thanking Mr. H. Bolas, of the Air Department, Admiralty, for his valuable criticisms upon the proofs. My thanks are also due to Mr. T. E. Ritchie for his help in reading through the proofs, and to Mr. A. King for his assistance in the compiling of the various diagrams.

The Controller of His Majesty's Stationery Office has permitted me to quote from certain of the Technical Reports of the Advisory Committee for Aeronautics.

M. A. S. R.

HENDON.

CONTENTS

INTRODUCTION.

	PAGE
PRESSURE ON AEROFOILS	1

CHAPTER I.

THE PITCH OF AN AIR-SCREW	6
-------------------------------------	---

CHAPTER II.

THE FORCES ACTING ON AN AIR-SCREW BLADE	14
---	----

CHAPTER III.

BLADE SHAPE AND EFFICIENCY	25
--------------------------------------	----

CHAPTER IV.

BLADE SECTIONS, AND WORKING FORMULÆ	47
---	----

CHAPTER V.

"LAYING OUT" THE AIR-SCREW	72
--------------------------------------	----

CHAPTER VI.

STRESSES IN AIR-SCREW BLADES	77
--	----

CHAPTER VII.

STATIC THRUST	86
-------------------------	----

	PAGE
CHAPTER VIII.	
EFFICIENCY OF AN AIR-SCREW AT DIFFERENT SPEEDS OF TRANSLATION	91

CHAPTER IX.

DIRECT LIFTING SYSTEMS	109
----------------------------------	-----

APPENDIX I.

NOTE ON THE INFLUENCE OF "ASPECT RATIO"	121
---	-----

APPENDIX II.

NOTE ON THE EFFECT OF THE INDRAUGHT IN FRONT OF AN AIR-SCREW	123
---	-----

INDEX	125
-----------------	-----

AIR-SCREWS

INTRODUCTION.

PRESSURE ON AEROFOILS.

THE problem of determining the form of air flow generated by an aerofoil, moving through still air, is one that has so far defied mathematical analysis. This problem, which applies equally to water and other fluids, is one for which a solution has only been obtained when the aerofoil is a flat plate of infinite span.* The analytical results however do not conform with those obtained by experiment, and it would seem that the still more complex problem of the curved surface is beyond the reach of present-day analysis.

The mathematical theory makes the pressure on a flat surface vary as the square of the general velocity of the stream, and experiment has shown that between fairly large limits in velocity this holds good.

Briefly, if an aerofoil be exposed to a moving current of air or, what is the same thing, if an aeroplane wing be moving through still air, the resultant air pressure on the aerofoil may be expressed by the formula ($R = k.S.V^2$), where (S) denotes the area of the aerofoil surface, and (V) the velocity of flight of the aerofoil relative to the air. (k) is a constant the numerical value of which depends upon the units employed in the measurements of the quantities (R), (S), and (V).

* A further development has recently been obtained by Professor G. H. Bryan and Mr. R. Jones. "Discontinuous Fluid Motion past a Bent Plane, with Special Reference to Aeroplane Problems." By G. H. Bryan, Sc.D., F.R.S., and Robert Jones, M.A. (Proceedings of the Royal Society, Vol. 91, No. A 680).

It can easily be seen that (k) has thus the dimensions of density. If we introduce the density of the air into the equation, we can write ($R = c.\rho.S.V^2$), where (ρ) denotes atmospheric density, and the constant (c) is then non-dimensional.

The resultant pressure (R) is composed of two quantities, the pressure on the under surface of the aerofoil and the negative pressure on the top surface of the aerofoil. This latter as a rule forms the principal portion of (R) and in many cases is from three to four times as large as the pressure on the under surface.

(R) can be split up into two components, measured normal to, and tangential with, the line of flight of the aerofoil. These two components are termed the lift and drag components respectively, and the value of their ratio is termed the lift-drag ratio of the aerofoil.

Since (c) has been shown to be non-dimensional, the two constants in the expressions for the lift and drag will also be non-dimensional, and accordingly we may write

$$\begin{aligned} L &= c_y.\rho.S.V^2, \\ D &= c_x.\rho.S.V^2, \end{aligned}$$

where the suffixes (y) and (x) affixed to (c) denote vertical and horizontal components respectively.

(c_y) and (c_x) are known as the absolute lift coefficient and absolute drag coefficient respectively.

From the above it can be seen that the ratio $\frac{L}{D}$ is equal to the ratio $\frac{c_y}{c_x}$, and so, when estimating the value of the lift-drag ratio of an aerofoil, it is unnecessary to know the value of the actual pressures concerned; it is sufficient to know the value of each of the coefficients.

The value of this ratio $\frac{c_y}{c_x}$ is of great importance in aeroplane design, and the suitability of an aerofoil shape as a wing section depends largely upon this value.

It is always desirable to make this ratio as large as possible.

This also applies to the theory of air-screw design based on the aerofoil analogy.

In records of experimental results, the reciprocal of this ratio is sometimes used.

The ratio $\frac{c_y}{c_x}$ can also be expressed as $\cot \gamma$, where γ denotes the gliding angle of the aerofoil.

The numerical values of (c_y) and (c_x) are found to vary with variations in the angle of the chord incidence of the aerofoil with the direction of motion, and their values are usually given over a large range of angles.

For many forms of aerofoil, the angle corresponding with the highest value of $\frac{c_y}{c_x}$ is found to be in the neighbourhood of 4° .

The value of (c) for normal incidence, e.g. "broad side on," of a flat surface of infinite span is ($\cdot 44$) on the modern mathematical theory, the actual value found from experiment being ($\cdot 64$).

There is another quantity upon which the values of (c_y) and (c_x) depend to a certain extent. This quantity is the ratio of the lengths of the span to the chord of an aeroplane wing. It is commonly known as the "Aspect Ratio."

Model aerofoils used for purposes of testing in a wind tunnel usually have a value of (6) for this ratio. As a rule the higher the value of the aspect ratio, the higher the value of $\frac{c_y}{c_x}$.

It can hardly be said that there is anything essentially new in the development of a theory of air-screws from the analogy presented with the motion of an aerofoil in a straight line.

This subject was first investigated by Drzewiecki in 1882 and has since been developed by Lanchester.*

The fundamental hypothesis underlying the whole theory here set forth is that :

(1) Each infinitesimal element along the blade of an air-screw may be treated as a separate aerofoil possessing the same characteristics as those which an aerofoil, having the same shape

* "Aerial Flight," by F. W. Lanchester.

and having an aspect ratio equal to the aspect ratio of the whole air-screw, would possess ;

(2) The velocity of each blade element, compounded of the translational velocity and the circumferential velocity, at the point in question, may be treated as causing no appreciable variation from the V^2 law, so that the infinitesimal pressures on every element of the blade may be considered as satisfying the relation $R = c.\rho.S.V^2$.

Messrs. F. H. Bramwell and A. Fage, of the National Physical Laboratory, say with reference to the application of these assumptions:—*

“There are at present two systems mainly employed in the design of propellers. The first, which is generally used in the design of marine propellers, consists in making small variations from existing successful designs: it is necessary that no very great variation should be made at any one time.

“The second, which has so far been used almost exclusively for the design of aerial propellers, attempts to predict the performance of a propeller from a consideration of the forces on elementary strips of the blade. This method, if sensibly correct, is far more powerful than the older one, as it affords a means of introducing new features irrespective of whether the variation from existing types is small or large.

“The initial assumptions underlying this method, which has been developed by Lanchester and Drzewiecki, are that the forces on the blades are due directly to the velocities of the various sections relative to still air, these velocities being compounded of the translational velocity and the circumferential velocity at the point in question, and also that the sections may be treated independently. . . .

“The final conclusion arrived at is that although the method is not strictly correct, yet in the hands of a careful designer it is probably by far the best method that can be used for the design of propellers in the present state of knowledge on the subject. . . .

“The question of practical importance, however, is whether

* “Technical Report of the Advisory Committee for Aeronautics, 1912-18.”

the theory affords a sufficient basis for purposes of design. When examined from this point of view it is found that, if the range of comparison be limited to that usual in flying machines, the experimental and calculated results are in sufficiently good agreement, and that so long as the conditions under which the propeller is working are not varied too widely, the theory may be satisfactorily applied. The occasional failure of propellers to satisfy the conditions of design may be due to an overstepping of these limits. In most cases the differences between the calculated and experimental results are not sufficiently large for their effects to be observed in the flying of the completed aeroplane. . . .

“On the other hand, it is more probable that most of the discrepancies are due to the centrifugal forces on the air in contact with the blade; this must alter the character of the flow round the blade very considerably, and it is perhaps a matter for surprise that the agreement between the calculated and experimental values is as close as it is, and not that they do not agree exactly.”

CHAPTER I.

THE PITCH OF AN AIR-SCREW.

It is fairly obvious that when an air-screw is moving through the air with some definite translational velocity the distance it traverses in each revolution will be constant, providing the line of flight be horizontal.

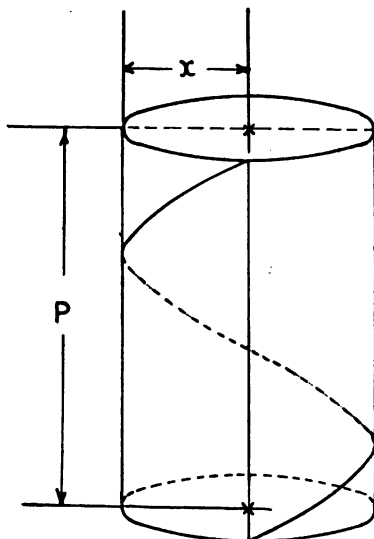

FIG. 1.

Now if we consider any portion of the blade at a distance of (x) feet say from the centre of the boss of the air-screw, we shall find that as the air-screw as a whole moves forward, the portion of the blade under consideration moves up some particular helicoidal path due to the air-screw rotating about its axis at the boss centre.

The steepness of the helix traversed by the portion of the blade at radius (x) will depend upon the value of the distance traversed translationally by the air-screw in each revolution.

It will also depend upon the value of (x), that is upon the distance of the portion of the blade considered from the centre of the boss of the air-screw.

This may perhaps be more clearly visualized if we imagine

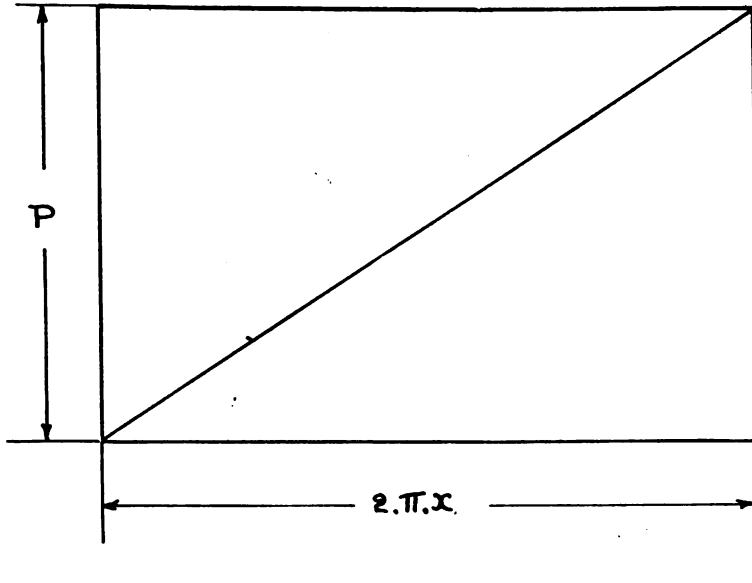

FIG. 2.

a cylinder having a radius of (x) and a depth of (P), as in Fig. (1).

Or it may be demonstrated by taking a rectangular piece of paper and drawing a diagonal line as in Fig. (2).

Then if the paper be rolled so as to form a cylinder having both ends open, the diagonal line will represent the path or helix traversed by the point under consideration; the diameter of the cylinder so formed will represent twice the distance of the point considered from the centre of the cylinder (i.e. the centre of the boss of the air-screw).

The circumference of the base of the cylinder will represent

the path that would be traced out, by the point considered, in one revolution, if the air-screw was not moving forward at all, but merely revolving on its axis ; and the length of this circumference can be seen to be equal to

(π) .(the diameter of the cylinder),

that is $(2.\pi.x)$, where (x) is the distance of the walls of the cylinder from the centre of the cylinder, corresponding to the

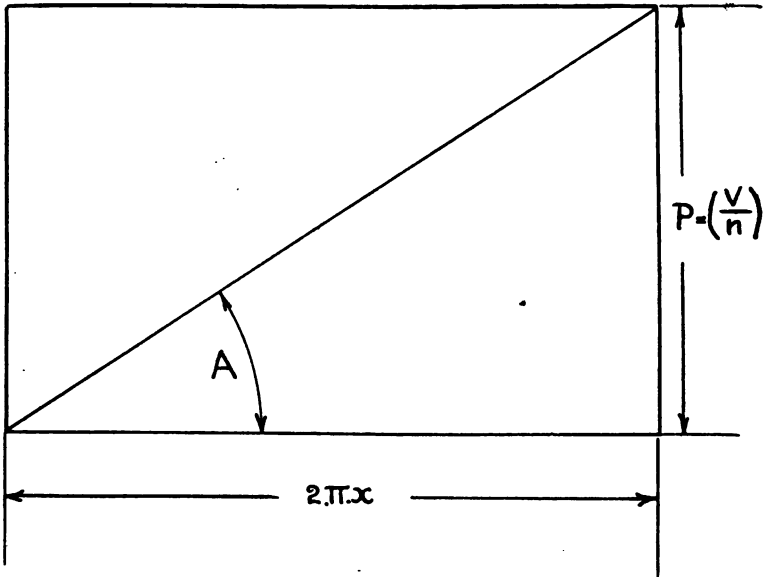

FIG. 3.

distance of the portion of the air-screw blade considered from its boss centre.

And the depth of the cylinder will then represent the distance advanced through translationally by the point, and therefore by the whole air-screw, at each revolution.

If the paper cylinder be now flattened out as in (Fig. 3), it at once becomes apparent that the helix traversed by the point in each revolution of the air-screw is the hypotenuse of a right-angled triangle, and therefore that its length is equal to $\sqrt{P^2 + 4.\pi^2.x^2}$, by Euclid I. 47.

Let us denote the angle which the helix line makes with the base by $(A)^\circ$. Then if (V) ft./sec. be the translational velocity and (n) the number of revs./sec. of the air-screw, we see that the distance advanced in each revolution translationally is $\frac{V}{n}$ feet. This distance we shall here denote by (P) , and (P) is then defined as being the effective pitch of the air-screw.

We have so far only considered the path traced out by one portion of the blade at a radius of (x) . Suppose that we have a large number of paper cylinders, each having the same depth but of varying diameters. Then their respective diagonals

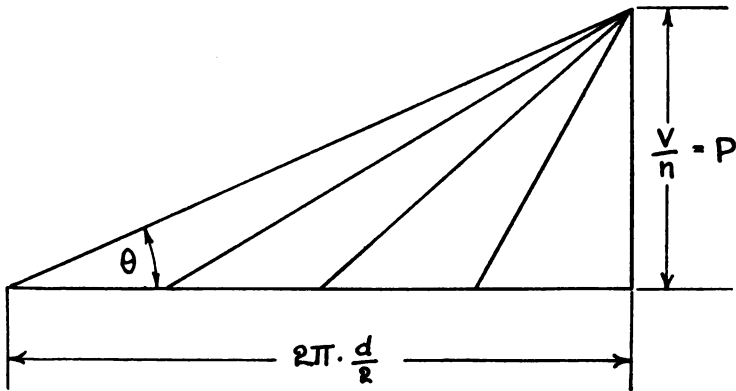

FIG. 4.

will represent the respective helicoidal paths traced out by the various portions of the blade. It is at once obvious that to completely portray the paths traced out by every portion of the blade we should require an infinite number of such cylinders.

We can, however, do this very easily for a limited number of different parts of the blade by drawing a right-angled triangle having a base equal to

$$(2\pi) \cdot (\text{half the diameter of the air-screw}),$$

and having straight lines drawn from the vertex of the triangle to various points along the blade, as in Fig. (4).

The height of the triangle is then, as before, equal to (P) ,

the effective pitch, and the angles formed by the various lines at the base of the triangle represent the helix angles of the respective portions of the blade considered.

We may denote these angles by (A_1, A_2, A_3, \dots) corresponding to radii from the boss centre of (x_1, x_2, x_3, \dots) .

The helix angle of the blade tip, that is the angle at a radius equal to half the diameter of the air-screw, may be denoted by (θ) .

It can be seen from the figure that since all the helicoidal paths of the various portions of the blade meet in a point, they must all satisfy the relation

$$\tan A = \frac{P}{2.\pi.x}, \text{ so that } A = \tan^{-1} \left(\frac{P}{2.\pi.x} \right),$$

giving the value of the helix angle (A) in degrees for any radius (x) from the boss centre of the air-screw, providing the value of (P) be known.

Now suppose that we have an air-screw, and that we measure the actual chord angles of the blade to the disc of revolution at various distances from the boss centre.

Let us denote these various chord angles by $(\phi_1, \phi_2, \phi_3, \dots)$, corresponding to radii of (x_1, x_2, x_3, \dots) from the centre of the boss.

In some types of air-screws, these angles are designed so that they all satisfy the relation

$$\phi = \tan^{-1} \left(\frac{P}{2.\pi.x} \right),$$

(ϕ) being any chord angle measured along the blade.*

Air-screws of such a type are sometimes said to be of "constant pitch," although this term is somewhat misleading. It must not be confused with the "effective pitch" already defined.

The above condition of an air-screw having a "constant pitch" is however in the nature of a restriction, and we shall

* (P) does not necessarily here denote the value of $\frac{V}{n}$, but usually has a larger value than the effective pitch of the air-screw.

therefore start with the assumption that the chord angles ($\phi_1, \phi_2, \phi_3, \dots$) have no specified connection, but that they may be anything whatever.

Now suppose our air-screw, having the chord angles ($\phi_1, \phi_2, \phi_3, \dots$) as defined, to have a translational velocity of (V) feet/sec. and a speed of revolution of (n) revs./sec., then the distance advanced through in the direction of translation per revolution is $\frac{V}{n}$ feet, and has already been defined as being the effective pitch of the air-screw.

Suppose that we keep (n) constant, and give to (V) the successive values of (V_1, V_2, V_3, \dots).

Then the distances advanced through at each revolution will be $\frac{V_1}{n}, \frac{V_2}{n}, \frac{V_3}{n}, \dots$

Thus it is possible to have an infinite number of values for the effective pitch of any given air-screw, corresponding to an infinite number of values of the translational velocity (V).

It is obvious therefore that the effective pitch of any air-screw is not necessarily a fixed quantity, but depends upon the values of (V) and (n).

It is usual however to associate the pitch of a screw with the screw itself, and thus to imagine it to be a fixed quantity for any given screw.

In order to determine some analogous expression, in the case of an air-screw, which is a constant quantity for any given type of air-screw, we may define a particular value of the ratio $\frac{V}{n}$ at which there is

- (1) no resultant thrust on the blades in the direction of translation;
- (2) no resultant torque on the blades in a direction normal to the direction of translation, and therefore tangential to the disc of revolution of the blades;
- (3) no "average" reaction on the blades.

The three values of $\frac{V}{n}$ corresponding to these three cases will be constants for any given type of air-screw.

The quantitative determination of these values of the effective pitch may be found from the results of the analysis to be proved later.

We may denote these values of (P) by (P_1) , (P_2) , and (P_3) , or by $(\frac{V}{n})_1$, $(\frac{V}{n})_2$, and $(\frac{V}{n})_3$.

The "experimental mean pitch" of an air-screw has been

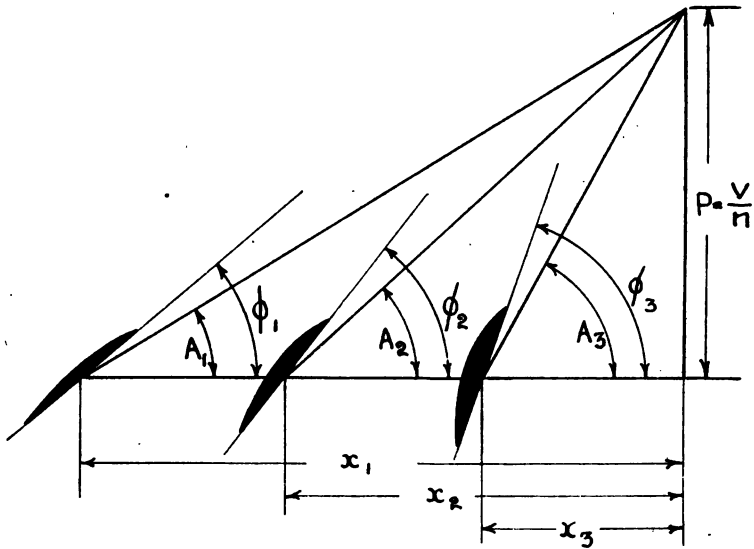

FIG. 5.

defined by Mr. F. H. Bramwell as being the value of the ratio $\frac{V}{n}$ for which there is no thrust on the blades in the direction of translation.

This definition corresponds to (1) already given.

Suppose then that our air-screw receives a velocity of translation of (V) feet/sec., and therefore has some definite value of $\frac{V}{n}$, the effective pitch.

Denoting the helix angles along the blade at radii of (x_1, x_2, x_3, \dots) by (A_1, A_2, A_3, \dots) and the chord angles by ($\phi_1, \phi_2, \phi_3, \dots$) we may represent the paths of the various portions of the blade considered by Fig. (5).

We have made the chord angles in each case greater than the corresponding helix angles for the sake of clearness.

Then it is obvious that, since each of the blade elements considered is moving up the hypotenuse of one of the corresponding right-angled triangles, the actual angles at which these blade elements move to their respective helicoidal paths are ($\phi_1 - A_1$), ($\phi_2 - A_2$), ($\phi_3 - A_3$), \dots , and these angles are analogous to the chord angles of incidence of an aeroplane wing in flight. They are here denoted by (a_1, a_2, a_3, \dots) and are termed the "angles of attack" of the various blade elements considered.

Since the angles ($\phi_1, \phi_2, \phi_3, \dots$) are perfectly arbitrary, these angles of attack are likewise arbitrary and may be made anything that is convenient.

CHAPTER II.

THE FORCES ACTING ON AN AIR-SCREW BLADE.

Now it has already been stated that if an aerofoil be moving in a straight line at a velocity of (V), the two components, normal to and tangential with its line of flight, of the resultant pressure exerted upon it by the air can be written

$$\begin{aligned} L &= c_y \cdot \rho \cdot S \cdot V^2, \\ D &= c_x \cdot \rho \cdot S \cdot V^2, \end{aligned}$$

and we have the obvious relation already mentioned,

$$\frac{L}{D} = \frac{c_y}{c_x} = \cot \gamma,$$

(γ) being the gliding angle of the aerofoil at the particular angle of incidence to its line of flight considered.

(γ) is the angle which the direction of the resultant air-pressure on an aerofoil makes with the direction of the vertical component of (R), that is the lift.

It will be noticed that the blade sections of an air-screw are similar to those used on aeroplane wings, and hence it at once raises the question: Cannot we treat the sections along an air-screw blade as if they were aeroplane wings moving at angles of incidence of (a_1, a_2, a_3, \dots)?

It is upon this very assumption that the whole of the theory of air-screw design is based, as already explained in the Introduction.

It is also obvious that, in order to be able to correctly follow out the consequences of this assumption, we must treat each of the portions of the blade as being of infinitely small breadth in the direction of the radius (x).

We may then without error sum up the forces on all these infinitely narrow blade strips, and hence obtain a correct quantitative determination of the characteristics of the air-screw.*

This is of course the ordinary mathematical process of integration.

Let us then consider the forces acting upon a strip of blade

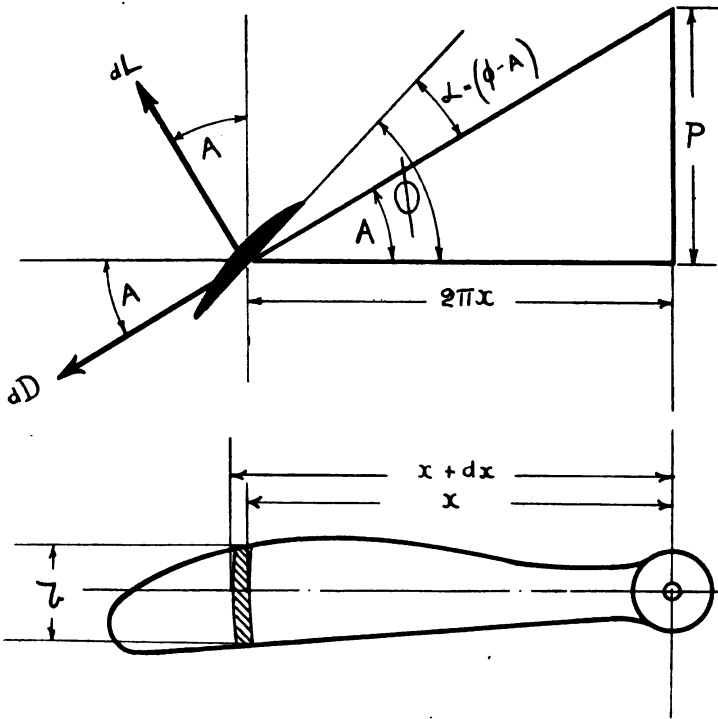

FIG. 6.

at a radius of (x) from the boss centre of the air-screw. Fig. (6) shows the two views of the blade, in side elevation and plan.

Since the element of blade is moving up the hypotenuse of the right-angled triangle, the two components of the resultant

* This is of course an assumption of the theory.

air-pressure upon it will be normal to and tangential with the hypotenuse of the triangle respectively.

These infinitesimal pressures may be denoted by (dL) and (dD).

Let the width of the blade at radius (x) be denoted by (b). Then, applying the formulæ for air-pressure, we have

$$dL = c_y \cdot \rho \cdot b \cdot dx \cdot v^2,$$

and

$$dD = c_x \cdot \rho \cdot b \cdot dx \cdot v^2.$$

And the value of (v) is obviously equal to $n \cdot \sqrt{P^2 + 4 \cdot \pi^2 \cdot x^2}$, for, as already shown, the quantity $\sqrt{P^2 + 4 \cdot \pi^2 \cdot x^2}$ is the length of the helix traversed by the element of blade at each revolution of the air-screw, and hence the distance traversed by the element per second is (n) times this amount, where (n) is equal to the number of revolutions of the air-screw per second.

Whence the velocity of the blade element is $n \cdot \sqrt{P^2 + 4 \cdot \pi^2 \cdot x^2}$. So that we have

$$dL = \rho \cdot n^2 \cdot c_y \cdot b \cdot (P^2 + 4 \cdot \pi^2 \cdot x^2) \cdot dx,$$

$$dD = \rho \cdot n^2 \cdot c_x \cdot b \cdot (P^2 + 4 \cdot \pi^2 \cdot x^2) \cdot dx.$$

Now we are not immediately concerned with (dL), but with its components normal to and tangential with the disc of revolution of the blade.

These are

$$(dL \cdot \cos A) \text{ and } (dL \cdot \sin A) \text{ respectively.}$$

Again, consider the value of (dD), the drag of the element.

We have

$$dD = \rho \cdot n^2 \cdot c_x \cdot b \cdot (P^2 + 4 \cdot \pi^2 \cdot x^2) \cdot dx,$$

and this may also be split up into two components normal to and tangential with the disc of revolution of the blade.

These components are

$$(-dD \cdot \sin A) \text{ and } (dD \cdot \cos A) \text{ respectively.}$$

Now the thrust on the element is measured by the components of all the forces acting on the element in a direction

normal to the disc of revolution of the blade, that is, parallel with the line of advance of the air-screw.

The forces so acting are seen to be

$$(dL. \cos A) \text{ and } (-dD. \sin A),$$

so that the resultant force on the element in a direction normal to the disc of revolution of the air-screw is $(dL. \cos A - dD. \sin A)$, and this may be denoted by (dT) , the elementary thrust on the element.

In a similar manner it can be shown that the remaining forces make up a total force in a direction tangential to the disc of revolution of the air-screw, and of amount

$$(dL. \sin A + dD. \cos A).$$

This force comprises the drag or resistance exerted by the element to circular motion, and is analogous to a friction brake applied to the rim of a revolving wheel. It tends to retard the motion.

It can be seen that the product of the above quantity and the distance (x) of the element from the boss centre measures the torque of the element.

Thus, denoting the torque by (dM) , we have

$$dM = x. (dL. \sin A + dD. \cos A),$$

and we have already shown that the thrust on the element may be expressed by

$$dT = (dL. \cos A - dD. \sin A).$$

From these two equations and from the equation already obtained for the lift on the aerofoil, we can solve all the problems presented in the design of air-screws.

We have

$$dT = dL. \cos A - dD. \sin A,$$

and we know that

$$\tan \gamma = \frac{c_x}{c_y} = \frac{\text{drag}}{\text{lift}} = \frac{dD}{dL},$$

whence, substituting, we obtain

$$dT = \rho.n^2.c_y.b. (2.\pi.x - P. \tan \gamma).\sqrt{P^2 + 4.\pi^2.x^2}. dx,$$

and therefore

$$T = \rho.n^2. \int_{r_0}^r c_y.b. (2.\pi.x - P. \tan \gamma).\sqrt{P^2 + 4.\pi^2.x^2}. dx,$$

giving the total thrust on *each* blade of the air-screw.

(r) denotes the length of each blade from the boss centre.

(r_0) denotes the length from the boss centre to the extreme portion of the blade where the "streamlining" of the sections ceases. As a rule, in determining approximate values for the integrals, we may take (r_0) as equal to zero without appreciable error.

We have also

$$\begin{aligned} dM &= x. (dL. \sin A + dD. \cos A) \\ &= \rho.n^2.c_y.b.x. (P + 2.\pi.x. \tan \gamma).\sqrt{P^2 + 4.\pi^2.x^2}. dx, \end{aligned}$$

and therefore

$$M = \rho.n^2. \int_{r_0}^r c_y.b.x. (P + 2.\pi.x. \tan \gamma).\sqrt{P^2 + 4.\pi^2.x^2}. dx.$$

And since ($M.2.\pi.n$) is proportional to the B.H.P. required to turn each blade of the air-screw, we can at once determine the necessary value of the blade width at each radius to satisfy any given set of conditions.

We are now in a position to write down the efficiency of the whole blade, that is, of the air-screw.

The work done per revolution by the air-screw is the product of the total thrust exerted and the distance through which it is exerted, that is, the quantity having the value of $\frac{V}{n}$ and defined as the effective pitch of the air-screw.

Let (N) denote the number of blades of the air-screw.

Then we have

$$\text{work done by air-screw per revolution} = (N.T.P.),$$

and

$$\begin{aligned} \text{work done by motor per revolution in} \\ \text{turning the air-screw at } (n) \text{ revs./sec.} &= (N.M.2.\pi), \end{aligned}$$

and therefore the efficiency of the whole air-screw is given by

$$\eta = \frac{\text{N.T.P.}}{\text{N.M.}2.\pi.}$$

$$\text{and } \therefore \eta = \frac{P. \int_{r_0}^r b.c_y. (2.\pi.x - P. \tan \gamma). \sqrt{P^2 + 4.\pi^2.x^2}. dx}{2.\pi. \int_{r_0}^r b.c_y.x. (P + 2.\pi.x. \tan \gamma). \sqrt{P^2 + 4.\pi^2.x^2}. dx}$$

This gives the general formula for the efficiency of any type of air-screw, for any specified value of $\frac{V}{n}$.

We may now endeavour to determine the values of the pitch, corresponding to no thrust on the blades, to no torque on the blades, and to no resultant "average" reaction on the blades.

The first of these quantities is called the "Experimental Mean Pitch," and we shall now endeavour to determine by calculation the value of this quantity for any given set of conditions.

This value of the ratio $\frac{V}{n}$ is usually determined for any given air-screw experimentally in a wind-tunnel.

The method to determine this theoretically is as follows.

We have already shown that the expression for the thrust on each blade of *any* given type of air-screw may be written as

$$T = \rho.n^2. \int_{r_0}^r c_y.b. (2.\pi.x - P. \tan \gamma). \sqrt{P^2 + 4.\pi^2.x^2}. dx,$$

where $P = \frac{V}{n}$.

Now if $T = 0$, then since $(\rho.n^2)$ is finite we have

$$0 = \int_{r_0}^r c_y.b. (2.\pi.x - P. \tan \gamma). \sqrt{P^2 + 4.\pi^2.x^2}. dx,$$

$$\begin{aligned} \text{i.e.} \quad & 2.\pi. \int_{r_0}^r c_y . b . x . \sqrt{P^2 + 4.\pi^2 . x^2} . dx \\ & = P . \int_{r_0}^r c_y . b . \tan \gamma . \sqrt{P^2 + 4.\pi^2 . x^2} . dx \end{aligned}$$

And this may be solved graphically as follows.

Take successive values of (P) from some value greater than what would correspond to the effective pitch of the air-screw upwards, and plot the two graphs $2.\pi.c_y.b.x.\sqrt{P^2+4.\pi^2.x^2}$ and $P.c_y.b.\tan \gamma.\sqrt{P^2+4.\pi^2.x^2}$ against (x) between (r_0) and (r) for each of the values of (P) taken. Take the areas of the two figures thus obtained in each case. When the two areas in any case are numerically equal, then the value of (P) taken for this case is the value of the "experimental mean pitch" of the air-screw.

It is of course apparent that the values of (c_y) and ($\tan \gamma$) will vary with each value of (P) taken.

We can, however, determine their respective values in the following manner.

Let us denote the successive arbitrary values of (P) taken by (P' , P'' , P''' ,), and let us suppose that $P' < P'' < P''' < \dots$

Moreover, let us denote the chord angles along the blade of the air-screw by (ϕ_1 , ϕ_2 , ϕ_3 ). Then if (A_1' , A_2' , A_3' ) be the helix angles at radii (x_1 , x_2 , x_3 ) respectively, for a value of $\frac{V}{n}$ equal to the first value of (P) taken, namely (P'), the value of each of these helix angles at any radius (x) will be given by the relation

$$A' = \tan^{-1} \left(\frac{P'}{2.\pi.x.} \right).$$

And therefore the values of the respective angles of attack of the sections at these radii will be given by

$$a' = (\phi - A') = \phi - \tan^{-1} \left(\frac{P'}{2.\pi.x.} \right)$$

for the particular value (P') considered.

Similarly, it may be shown that the angles of attack of the sections for the other values of (P) taken, namely (P', P''), will be given by

$$\alpha'' = \phi - \tan^{-1} \left(\frac{P''}{2\pi x} \right),$$

$$\alpha''' = \phi - \tan^{-1} \left(\frac{P'''}{2\pi x} \right), \text{ etc.}$$

Now measure up the forms of the sections of the blade at, say, (8) different radii. Then, if the sections so obtained are ones that have been tested as aerofoils in a wind-tunnel, we can at once write down their characteristics for any value of the angle of attack (α).

We may thus plot a series of graphs, for each of the arbitrary values of (P) taken, of (c_y) and ($\tan \gamma$) for the different radii taken along the blade.

If we then construct a series of such graphs for (c_y) and ($\tan \gamma$) for all the values of (P) taken, namely (P', P'', P'''), we shall be in a position to determine the value of the experimental mean pitch.

And we have to plot the two graphs already given for all the values of (P) taken.

In order to be able to plot these two curves in any case, we must draw out a curve of the actual blade widths against radii (x).

It then only remains to obtain the two areas enclosed by these two curves and the (x) axis. The value of (P) taken, which makes these two areas equal, is the value of the experimental mean pitch, corresponding to no thrust on the blade.

In a similar manner we can determine the value of $\frac{V}{n}$ for which there is no torque on the whole blade.

To determine the value of $\frac{V}{n}$ for which there is a zero value of the "average" reaction over the whole blade, it is first necessary to investigate the value of this resultant pressure at any radius (x), and so compute the value over the whole blade of the air-screw.

We shall then be in a position to estimate the value of $\frac{V}{n}$ for which this "average" resultant pressure over the whole blade is zero.

In order to obtain the value of this resultant pressure (R) we proceed as follows.

Consider a blade section at radius (x), and having a helix angle of (A), Fig. (7).

The resultant air-pressure (R) upon the section is usually

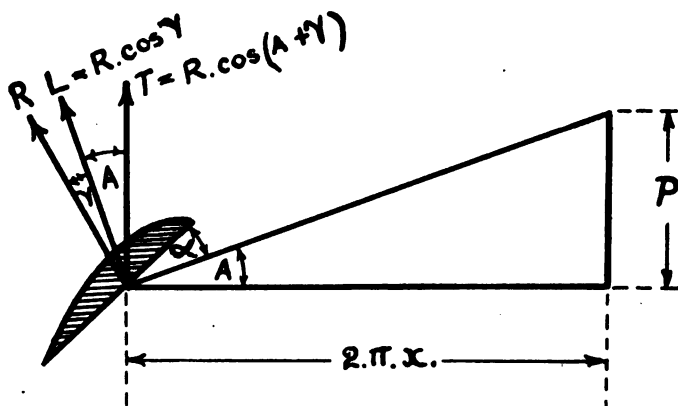

FIG. 7.

split up into two components called the lift and drag of the section. Let (γ) denote the gliding angle of the section.

Then

$$\text{Lift} = R \cos \gamma,$$

and

$$\text{Drag} = R \sin \gamma,$$

whence

$$\frac{\text{Lift}}{\text{Drag}} = \cot \gamma.$$

Now we have already shown that the resultant thrust on the section, in a direction parallel to the line of advance of the whole air-screw, is given by

$$T = L \cos A - D \sin A,$$

where (L) and (D) denote the lift and drag components of (R) respectively.

But

$$L = R. \cos \gamma,$$

and

$$D = R. \sin \gamma,$$

whence

$$L. \cos A - D. \sin A = R. \cos \gamma. \cos A - R. \sin \gamma. \sin A,$$

and therefore

$$T = R. \cos (A + \gamma),$$

whence

$$R = T. \sec (A + \gamma) \text{ for every point along the blade.}$$

It is also obvious that

$$\begin{aligned} \sec (A + \gamma) &= \frac{1}{\cos A. \cos \gamma - \sin A. \sin \gamma} \\ &= \frac{\sqrt{P^2 + 4.\pi^2.x^2}}{2.\pi.x. \cos \gamma - P. \sin \gamma} \end{aligned}$$

whence

$$R = \frac{T. \sqrt{P^2 + 4.\pi^2.x^2}}{\cos \gamma. (2.\pi.x - P. \tan \gamma)},$$

and this in strictness should be written

$$dR = \frac{dT. \sqrt{P^2 + 4.\pi^2.x^2}}{\cos \gamma. (2.\pi.x - P. \tan \gamma)},$$

since the pressures considered are infinitesimals

And $dT = \rho.n^2.b.c_y. (2.\pi.x - P. \tan \gamma). \sqrt{P^2 + 4.\pi^2.x^2}. dx,$
so that

$$dR = \rho.n^2.b.c_y. (P^2 + 4.\pi^2.x^2). \sec \gamma. dx,$$

whence

$$R = \rho.n^2. \int_{r_0}^r b.c_y. (P^2 + 4.\pi^2.x^2). \sec \gamma. dx,$$

and if this be now plotted against (x), we shall obtain the "Load Grading Curve" for the whole blade.

Since ($\tan \gamma$) is usually nearly constant between (r) and

(r_0), and also of small amount, we may write ($\sec \gamma$) equal to unity, and our expression for the total resultant force over the whole blade then becomes

$$R = \rho \cdot n^2 \cdot \int_{r_0}^r b \cdot c_y \cdot (P^2 + 4 \cdot \pi^2 \cdot x^2) \cdot dx,$$

and the curve obtained when integrating this expression graphically will not appreciably differ from the one obtained by inserting the rather troublesome ($\sec \gamma$) under the integral sign.

Having then obtained the value of (R) for each blade of the air-screw, we may proceed to determine the value of (P) for which (R) has a zero value, in the same manner as for the case of a zero value of the thrust on each blade.

In thus estimating this value of $\frac{V}{n}$ it will be prudent to insert the ($\sec \gamma$) in our expression for (R).

We have then

$$R = \rho \cdot n^2 \cdot \int_{r_0}^r b \cdot c_y \cdot (P^2 + 4 \cdot \pi^2 \cdot x^2) \cdot \sec \gamma \cdot dx,$$

and since (R) = 0, and ($\rho \cdot n^2$) is finite, we obtain

$$0 = \int_{r_0}^r b \cdot c_y \cdot (P^2 + 4 \cdot \pi^2 \cdot x^2) \cdot \sec \gamma \cdot dx.$$

Now ($\sec \gamma$) = $\sqrt{1 + \frac{c_x^2}{c_y^2}}$ and $\frac{c_x^2}{c_y^2}$ is always a positive quantity.

Hence ($\sec \gamma$) is always a positive quantity, and therefore (c_y) must be negative, when (R) is equal to zero, for at least some portion of the blade.

CHAPTER III.

BLADE SHAPE AND EFFICIENCY.

WE return now to a consideration of the formula already deduced for the efficiency of any type of air-screw blade.

It is obvious that, if the sections at every radius from the boss centre along the blade were of such a form (if it were possible) as to possess no drag, so that the value of $\frac{c_y}{c_x}$ would be infinite, the efficiency of the whole air-screw would be unity. That this is so may be seen by making $(\tan \gamma)$ equal to zero in the expression already obtained for the efficiency of any type of blade.

We have

$$\eta = \frac{P. \int_{r_0}^r c_y . b. (2.\pi.x - P. \tan \gamma). \sqrt{P^2 + 4.\pi^2.x^2}. dx}{2.\pi. \int_{r_0}^r c_y . b.x. (P + 2.\pi.x. \tan \gamma). \sqrt{P^2 + 4.\pi^2.x^2}. dx},$$

and now, making $(\tan \gamma) = 0$, we get

$$\eta = \frac{P. \int_{r_0}^r c_y . b. 2.\pi x. \sqrt{P^2 + 4.\pi^2.x^2}. dx}{2.\pi. \int_{r_0}^r c_y . b.x.P. \sqrt{P^2 + 4.\pi^2.x^2}. dx} = 1.$$

Unfortunately, however, $(\tan \gamma)$ never has the value of zero, although the smaller its value the higher the efficiency and *vice versa*.

It is obvious, since (b) is a function of the radius (x) , that the value of (η) will vary for different forms of blade outline,

and it therefore becomes necessary to find some form which will give as large a value as possible to (η) consistent with structural considerations.

Let us consider the efficiency of any blade element at radius (x) from the boss centre.

We have already shown that the nett thrust of the element, in a direction normal to the air-screw's disc of revolution, is given by

$$dT = dL \cos A (1 - \tan A \tan \gamma),$$

and that the nett drag of the element, in a direction tangential to the disc of revolution of the air-screw, may be written

$$\begin{aligned} dR^* &= dL \sin A + dD \cos A \\ &= dL \sin A (1 + \cot A \tan \gamma), \end{aligned}$$

and therefore the work done by the element per revolution of the air-screw is

$$dT.P = P.dL \cos A (1 - \tan A \tan \gamma),$$

and the work done by the motor in turning the element per revolution of the air-screw is

$$dR.2.\pi.x = 2.\pi.x.dL \sin A (1 + \cot A \tan \gamma),$$

whence the efficiency of the element is given by

$$\eta_A = \frac{P \cot A (1 - \tan A \tan \gamma)}{2.\pi.x (1 + \cot A \tan \gamma)} = \frac{\tan A}{\tan (A + \gamma)},$$

where the suffix (A) in (η_A) signifies the efficiency of an element at a helix angle of (A) .

We might also write this as (η_x) denoting the efficiency of an element at a radius of (x) . So that $(\eta_A) = (\eta_x)$.

If we require the efficiency of the element in terms of the radius (x) , we have

$$\eta_x = \frac{P (2.\pi.x - P \tan \gamma)}{2.\pi.x (P + 2.\pi \tan \gamma . x)}$$

We have thus shown that the efficiency varies at different points along the blade, and hence we can plot a curve of efficiencies against values of (x) . Such a curve is shown in Fig. (8).

* Not to be confused with the resultant pressure on an element, denoted by the same symbol.

The maximum point of efficiency along the blade may be found by putting

$$\frac{d\eta_A}{dA} = 0.$$

The point of maximum efficiency is found to be at a value of $(A) = 45^\circ - \frac{\gamma}{2}$, that is, in the neighbourhood of 43° .

Since $\tan A = \left(\frac{P}{2\pi \cdot x}\right)$, we can write

$$x = \frac{P}{2\pi \cdot \tan\left(45^\circ - \frac{\gamma}{2}\right)}, \text{ giving the value of } (x) \text{ for the}$$

maximum point of efficiency along the blade.

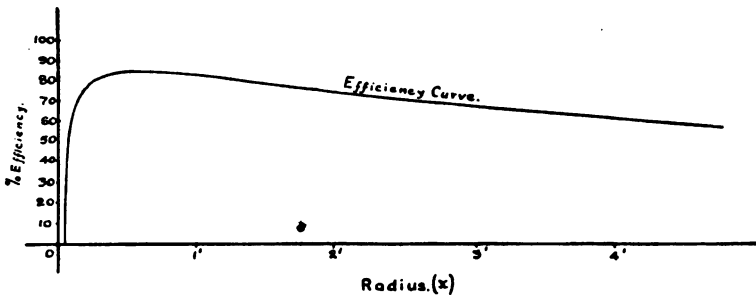

FIG. 8.

The point of maximum efficiency so obtained is only strictly true when (γ) is supposed to remain constant over the whole blade, that is, for every radius.

But in practice the values of $\frac{c_x}{c_y}$ for the various blade sections will not be found to vary very greatly, and hence the point of maximum efficiency will not fall very far short of that given by the formula.

It is obvious from the foregoing that the most efficient blade would be one in which the whole of the blade surface was concentrated at the point of maximum efficiency. The blade width (b) would then become infinite and the length of the blade in the direction of the radius (x) would be infinitesimal.

As, however, such a form of blade is impossible to construct we are forced to adopt a compromise between the width of the blade and the diameter of the air-screw.

Let us first consider the point along the blade at which the efficiency reaches a maximum value. We may regard (γ) as a variable, and we will denote it by $\tan^{-1} \psi(x)$, so that $\tan \gamma = \psi(x)$; then we have

$$\eta_x = \frac{P \cdot (2\pi x - P \cdot \psi(x))}{2\pi x \cdot (P + 2\pi x \cdot \psi(x))}$$

and for a maximum value of (η_x) , $\frac{d\eta_x}{dx} = 0$, and $\frac{d^2\eta_x}{dx^2}$ is negative.

So that

$$\begin{aligned} x \cdot (2\pi - P \cdot \psi'(x)) \cdot (P + 2\pi x \cdot \psi(x)) \\ = (2\pi x - P \cdot \psi(x)) \cdot (P + 4\pi x \cdot \psi(x) + 2\pi x^2 \cdot \psi'(x)), \end{aligned}$$

and this expression gives the value of (x) for which (η_x) is a maximum.

In order to evaluate the above it is necessary to know the form of the function $\psi(x)$, i.e. $(\tan \gamma)$.

If $(\tan \gamma)$ is constant over the whole blade, then $\psi'(x)$ vanishes, and the above expression reduces to

$$x = \frac{P}{2\pi \cdot \tan \left(45^\circ - \frac{\gamma}{2}\right)}$$

We thus obtain the original relation

$$A = 45^\circ - \frac{\gamma}{2}$$

for the angle at which the point of maximum efficiency occurs along the blade.

Now we have not as yet prescribed any particular value to (b) , the width of the blade at radius (x) .

In the majority of air-screw blades the value of (b) varies for different values of (x) , i.e. for different radii along the blade.

Now it is obvious that the blade should, from considerations of overall efficiency, be wider at some radii than at others. Hence in designing our blade we may plot a curve of propor-

tional blade widths against radii (x), so that the true or actual blade width for each value of (x) will be equal to the width shown on the curve multiplied by some constant.

We may thus write the blade width (b) as equal to the product of a constant and a function of (x), or

$$b = c.f(x).$$

Now we have already assumed that (γ) is a variable and may have different values for different values of (x), and we have denoted the ratio of $\frac{c_x}{c_y}$ by $\psi(x)$, so that

$$\begin{aligned}\tan \gamma &= \psi(x), \quad \text{and therefore} \\ \gamma &= \tan^{-1} \psi(x), \quad \text{as already given.}\end{aligned}$$

But if (γ) and therefore $\frac{c_x}{c_y}$ is a variable or function of (x), so also is (c_y), the absolute lift coefficient of the section at radius (x). Hence we may also write this in the form

$$(c_y) = \phi(x).$$

It has already been shown that

$$\eta_x = \frac{P. (2.\pi.x - P.\psi(x))}{2.\pi.x. (P + 2.\pi.x.\psi(x))}$$

which when plotted against radii (x) will give a curve of efficiency for each value of (x).

Now suppose we regard the curve so obtained as our proportional blade width curve, so that at each point along the blade the actual blade width is proportional to the efficiency at that point. We shall then ensure at any rate that our blade is widest at its most efficient point. This will not of course necessarily give the most efficient form of blade outline, but the efficiency of such a type of blade will be greater than that of one possessing the same characteristics in other directions but having a uniform blade width throughout.

If we turn to the "efficiency curve" already given, we shall notice the following.

(1) As (x) increases from zero up to about ($\frac{1}{4}$) the length of the blade, the efficiency rises very rapidly.

(2) As (x) increases, from the value corresponding to the point of maximum efficiency, to its maximum value (i.e. the length of the blade), the efficiency steadily decreases, although somewhat slowly compared with its initial rise from zero up to its maximum value.

(3) Hence, after the point of maximum efficiency has been reached, the blade becomes less and less efficient as we proceed to the tip. Hence the useful work done by the blade elements decreases towards the blade tip.

(4) This at once suggests the advisability of making the actual blade widths proportionally less at the outside radii than they would be if made exactly proportional to the efficiency curve. The second curve in Fig. (9) would then be a more

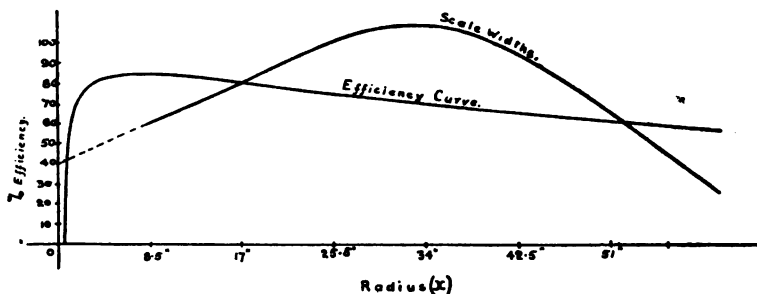

FIG. 9.

efficient shape than the efficiency curve. The maximum ordinate is now further to the right than in the efficiency curve.

There are however other considerations bearing upon the problem of the most efficient blade outline besides those already given.

If we pursue still further the analogy with an aeroplane wing, it at once becomes apparent that there may be a limit to the useful blade width possible in an air-screw.

In the case of an aeroplane having two or more superposed surfaces (e.g. as in a biplane) it is well known that the lift of the lower wing is affected quite appreciably by the "wash" of the top wing, and that the smaller the vertical distance between the two surfaces the greater is the loss in lift on the lower wing.

This vertical distance between the wings of an aeroplane is

known as the "gap," and the ratio between this distance and the width of each wing in the line of flight is known as the " $\frac{\text{gap}}{\text{chord}}$ " ratio. This ratio has usually a value of between ($\cdot 8$) and ($1\cdot 2$) and is often equal to unity in standard types of aeroplanes.

The value of this vertical distance or "gap" in the case of the blades of an air-screw is equal to

$$\frac{P \cdot \cos A}{N}$$

for an air-screw having (N) blades.

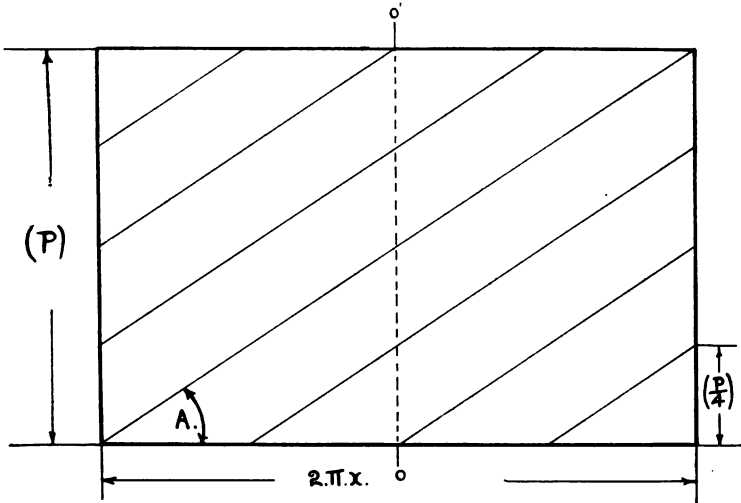

FIG. 10.

It is the value of the vertical distance between any two consecutive helicoidal paths after $\frac{1}{N}$ th of a revolution and after $\frac{2}{N}$ ^{ths} of a revolution respectively.

This may be illustrated if we have recourse once again to the paper cylinder.

Consider an air-screw having (4) blades. And draw on the rectangular piece of paper (7) parallel lines at equal distances apart, Fig. (10).

Now fold the paper into a cylinder having a depth as before of (P), Fig. (11). Then the lines so drawn will represent the helicoidal paths traced out by the same point on each of the (4) blades of the air-screw. We notice that the vertical distance or "gap" between any two such consecutive paths is equal to

$$\frac{P \cdot \cos A}{4}.$$

If then we make the width of the air-screw blade at any

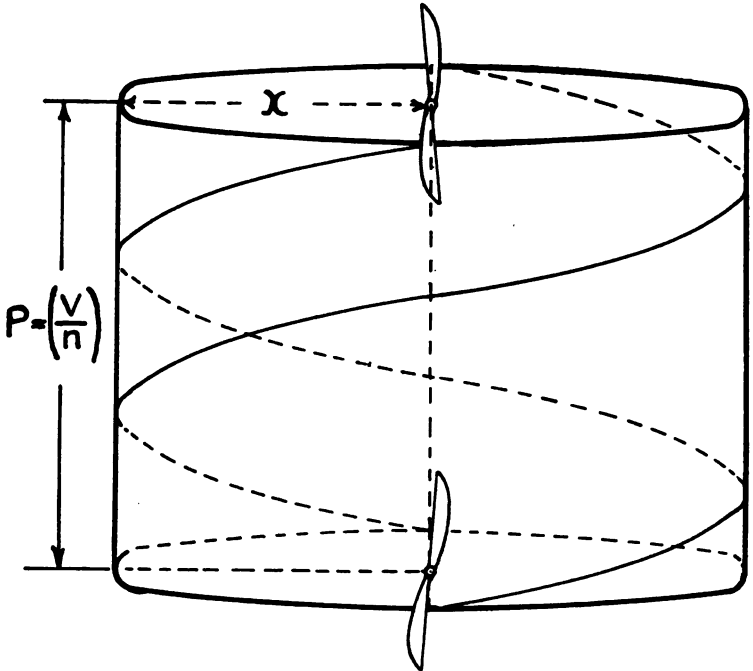

FIG. 11.

radius (x) proportional to the vertical distance between any two consecutive helicoidal paths, we introduce an allowance for possible blade interference, Fig. (12).

So that we have

$$b \propto \frac{P \cdot \cos A}{N},$$

whence

$$f(x) = \frac{P \cdot \cos A}{N} = \frac{2 \cdot \pi \cdot P \cdot x}{N \cdot \sqrt{P^2 + 4 \cdot \pi^2 \cdot x^2}}.$$

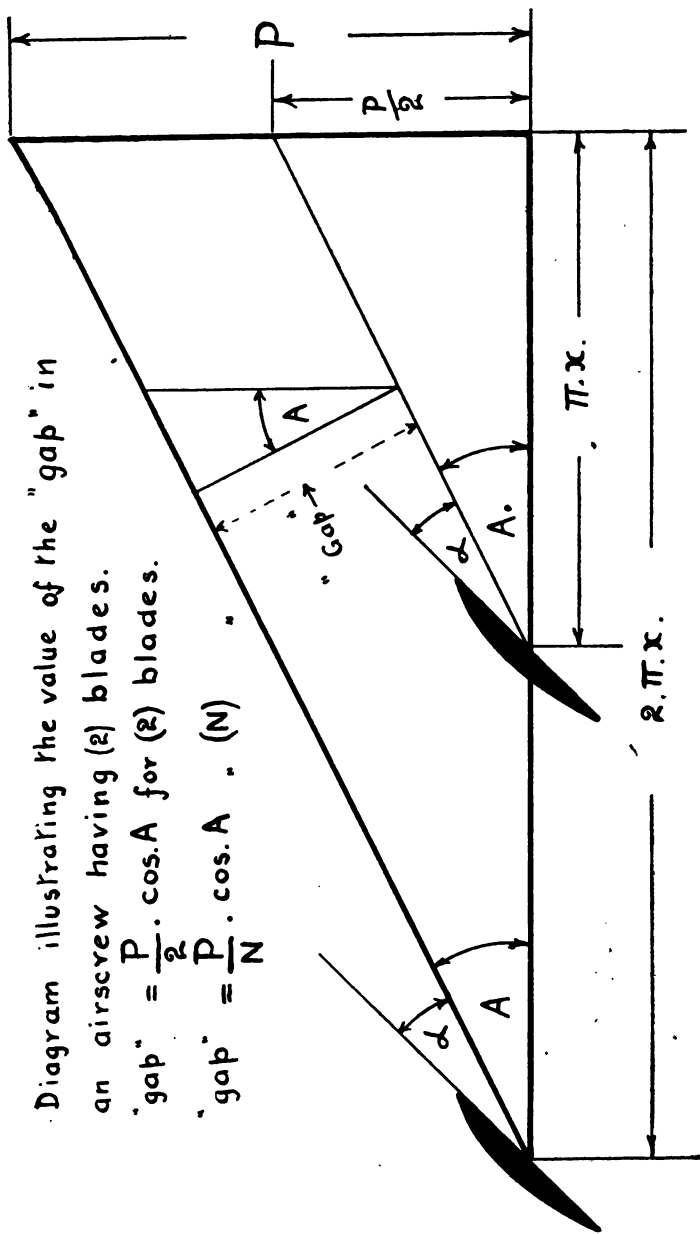

FIG. 12.

D

An air-screw having this type of blade outline has been called by Mr. A. R. Low the "Rational" blade. We shall refer to this type of blade by that name in what follows. There are other types of air-screw blades, and we shall now consider two of these further types.

The first type considered is one which would at first sight seem to be the simplest possible type of blade, the blade of uniform width. Here obviously (b) is independent of (x), since it is the same for all values of the radii.

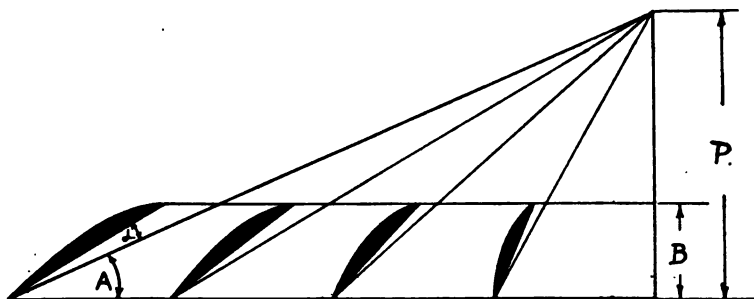

FIG. 18.

Hence (b) = constant = $c.f(x)$, whence $f(x) = 1$, and therefore (b) = (c).

And (c) has always the value of the ratio

$$\frac{\text{actual blade width at radius } (x)}{\text{scale blade width at radius } (x)}$$

In this case we can take the scale blade width as being equal to unity.

A blade having a constant chord width has been called by Mr. A. R. Low the "Normale" blade. We shall use this name when referring to this type of air-screw blade.

The second form of blade considered is one which from a constructional point of view forms the limiting curve of construction in which all the laminæ pass through the boss.

If in any type of air-screw the blade widths at any point come outside this curve, it is not possible to construct such a blade without using offsets on the laminæ.

Such a form of blade is shown in Fig. (13).

The form of blade outline is seen to be given by

$$b = B. \operatorname{cosec} (A + a),$$

whence

$$c.f(x) = B. \operatorname{cosec} (A + a),$$

and therefore

$$c = B, \quad \text{and} \quad f(x) = \operatorname{cosec} (A + a) = \frac{1}{\sin (A + a)},$$

and therefore

$$f(x) = \frac{\sqrt{P^2 + 4.\pi^2.x^2}}{P. \cos a + 2.\pi.x. \sin a},$$

and this expression does not greatly differ from

$$\frac{\sqrt{P^2 + 4.\pi^2.x^2}}{P},$$

the one obtained by making $(a) = 0$. This, as will be seen later, greatly simplifies the subsequent evaluation of the quantities characteristic of such a type of air-screw blade.

This form of blade may be termed the "Constructional Limit" type.

We shall now apply the formulæ already deduced for *any* type of air-screw blade to the four blade types already considered, namely:—

- (1) The "Efficiency Curve" type of blade outline.
- (2) The "Rational" type of blade outline.
- (3) The "Normale" type of blade outline.
- (4) The "Constructional Limit" type of blade outline.

The three expressions for Thrust, Torque, and Efficiency have been shown to be given by

$$T = \rho.n^2. \int_{r_0}^r c_y.b. (2.\pi.x - P. \tan \gamma). \sqrt{P^2 + 4.\pi^2.x^2}. dx,$$

which may be written as

$$T = \rho.n^2.c. \int_{r_0}^r f(x).\phi(x). (2.\pi.x - P.\psi(x)). \sqrt{P^2 + 4.\pi^2.x^2}. dx,$$

giving the Thrust exerted by *each* blade of the air-screw.

The Torque on *each* blade is given by

$$M = \rho.n^2. \int_{r_0}^r c_y.b.x. (P + 2.\pi.x. \tan \gamma). \sqrt{P^2 + 4.\pi^2.x^2}. dx,$$

which may be written as

$$M = \rho.n^2.c. \int_{r_0}^r f(x). \phi(x). x. (P + 2.\pi.x. \psi(x)). \sqrt{P^2 + 4.\pi^2.x^2}. dx.$$

The total Efficiency of each blade, and therefore of the whole air-screw, is given by

$$\eta = \frac{P. \int_{r_0}^r c_y.b. (2.\pi.x - P. \tan \gamma). \sqrt{P^2 + 4.\pi^2.x^2}. dx}{2.\pi. \int_{r_0}^r c_y.b.x. (P + 2.\pi.x. \tan \gamma). \sqrt{P^2 + 4.\pi^2.x^2}. dx},$$

which may be written as

$$\eta = \frac{P. \int_{r_0}^r f(x). \phi(x). (2.\pi.x - P. \psi(x)). \sqrt{P^2 + 4.\pi^2.x^2}. dx}{2.\pi. \int_{r_0}^r f(x). \phi(x). x. (P + 2.\pi.x. \psi(x)). \sqrt{P^2 + 4.\pi^2.x^2}. dx},$$

and we shall now apply these general results to the four types of blade outline considered.

“Efficiency Curve” type of blade outline.

$$\text{Here } f(x) = \frac{P. (2.\pi.x - P. \psi(x))}{2.\pi.x. (P + 2.\pi.x. \psi(x))},$$

so that the expression for the Thrust on *each* blade becomes

$$T = \frac{\rho.n^2.c.P}{2.\pi} \int_{r_0}^r \frac{\phi(x). \sqrt{P^2 + 4.\pi^2.x^2}. (2.\pi.x - P. \psi(x))^2. dx}{x. (P + 2.\pi.x. \psi(x))}.$$

The Torque on *each* blade is given by

$$M = \frac{\rho \cdot n^2 \cdot c \cdot P}{2 \cdot \pi} \int_{r_0}^r \phi(x) \cdot (2 \cdot \pi \cdot x - P \cdot \psi(x)) \cdot \sqrt{P^2 + 4 \cdot \pi^2 \cdot x^2} \cdot dx.$$

The total Efficiency of the whole blade is given by

$$\eta = \frac{P \cdot \int_{r_0}^r \frac{\phi(x) \cdot (2 \cdot \pi \cdot x - P \cdot \psi(x))^2 \cdot \sqrt{P^2 + 4 \cdot \pi^2 \cdot x^2} \cdot dx}{x \cdot (P + 2 \cdot \pi \cdot x \cdot \psi(x))}}{2 \cdot \pi \cdot \int_{r_0}^r \phi(x) \cdot (2 \cdot \pi \cdot x - P \cdot \psi(x)) \cdot \sqrt{P^2 + 4 \cdot \pi^2 \cdot x^2} \cdot dx}.$$

“Rational” type of blade outline.

$$\text{Here } f(x) = \frac{2 \cdot \pi \cdot P \cdot x}{N \cdot \sqrt{P^2 + 4 \cdot \pi^2 \cdot x^2}},$$

so that the expression for the Thrust on *each* blade becomes

$$T = \frac{2 \cdot \pi \cdot P \cdot \rho \cdot n^2 \cdot c}{N} \int_{r_0}^r x \cdot \phi(x) \cdot (2 \cdot \pi \cdot x - P \cdot \psi(x)) \cdot dx.$$

The Torque on *each* blade of the air-screw is given by

$$M = \frac{2 \cdot \pi \cdot P \cdot \rho \cdot n^2 \cdot c}{N} \int_{r_0}^r x^2 \cdot \phi(x) \cdot (P + 2 \cdot \pi \cdot x \cdot \psi(x)) \cdot dx.$$

And the total Efficiency of the whole blade is given by

$$\eta = \frac{P \cdot \int_{r_0}^r x \cdot \phi(x) \cdot (2 \cdot \pi \cdot x - P \cdot \psi(x)) \cdot dx}{2 \cdot \pi \cdot \int_{r_0}^r x^2 \cdot \phi(x) \cdot (P + 2 \cdot \pi \cdot x \cdot \psi(x)) \cdot dx}.$$

It will be noticed that in the case of these expressions for the “Rational” blade, the making of the blade width at any radius proportional to the “gap” has led to a great simplification being introduced into the results of the analysis.

This becomes at once apparent when we consider the particular case of uniform section over the whole blade.

$\phi(x)$ and $\psi(x)$ are then constants, and the three expressions given above can very easily be evaluated.

In this case the value of (c) , which is the value of the "chord" ratio of the blades, is usually chosen beforehand, gap and a good value for this constant appears to be about one-third to one-quarter. Mr. A. R. Low suggests the rule:

$$1 < m < 4, \text{ where } (m) \text{ is the reciprocal of } (c).$$

If (c) be evaluated from outside considerations of B.H.P. available, etc., and therefore from the formula given for the Torque, it is possible to see whether there is likely to be any appreciable interfering action between the blades due to forms of blade sections and therefore necessary blade widths used, etc.

"Normale" type of blade outline.

Here $(b) = (c)$, and $f(x) = 1$, so that the Thrust on *each* blade is given by

$$T = \rho \cdot n^2 \cdot c \cdot \int_{r_0}^r \phi(x) \cdot (2 \cdot \pi \cdot x - P \cdot \psi(x)) \cdot \sqrt{P^2 + 4 \cdot \pi^2 \cdot x^2} \cdot dx.$$

The Torque on *each* blade is given by

$$M = \rho \cdot n^2 \cdot c \cdot \int_{r_0}^r x \cdot \phi(x) \cdot (P + 2 \cdot \pi \cdot x \cdot \psi(x)) \cdot \sqrt{P^2 + 4 \cdot \pi^2 \cdot x^2} \cdot dx.$$

And the total Efficiency of the whole blade is given by

$$\eta = \frac{P \cdot \int_{r_0}^r \phi(x) \cdot (2 \cdot \pi \cdot x - P \cdot \psi(x)) \cdot \sqrt{P^2 + 4 \cdot \pi^2 \cdot x^2} \cdot dx}{2 \cdot \pi \cdot \int_{r_0}^r x \cdot \phi(x) \cdot (P + 2 \cdot \pi \cdot x \cdot \psi(x)) \cdot \sqrt{P^2 + 4 \cdot \pi^2 \cdot x^2} \cdot dx}.$$

“Constructional Limit” type of blade outline.

Here $f(x) = \frac{\sqrt{P^2 + 4\pi^2 x^2}}{P}$, so that the Thrust on *each* blade is given by

$$T = \frac{\rho \cdot n^2 \cdot c}{P} \cdot \int_{r_0}^r \phi(x) \cdot (2\pi x - P \cdot \psi(x)) \cdot (P^2 + 4\pi^2 x^2) \cdot dx.$$

The Torque on *each* blade is given by

$$M = \frac{\rho \cdot n^2 \cdot c}{P} \cdot \int_{r_0}^r x \cdot \phi(x) \cdot (P + 2\pi x \cdot \psi(x)) \cdot (P^2 + 4\pi^2 x^2) \cdot dx.$$

And the total Efficiency of the whole blade is given by

$$\eta = \frac{P \cdot \int_{r_0}^r \phi(x) \cdot (2\pi x - P \cdot \psi(x)) \cdot (P^2 + 4\pi^2 x^2) \cdot dx}{2\pi \cdot \int_{r_0}^r x \cdot \phi(x) \cdot (P + 2\pi x \cdot \psi(x)) \cdot (P^2 + 4\pi^2 x^2) \cdot dx}.$$

As can be seen from the above three expressions for Thrust, Torque, and Efficiency, the evaluation of each expression is a simple matter if we take $\phi(x)$ and $\psi(x)$ as being constants, that is if we assume the air-screw to have a uniform section throughout. The approximation thus introduced does not affect the accuracy of the expressions to such a material extent as might be expected. The main difficulty in the prediction of the performance of an air-screw lies in the shape of the blade outline not being as a rule readily capable of being expressed by some simple function of the radius (x).

We shall now determine a few values for the expressions already deduced for Thrust, Torque, and Efficiency, in the four cases already considered, when the blade section is assumed to be uniform throughout. This makes $\phi(x)$ and $\psi(x)$ constants, and we shall refer to these functions when considered as being constants by (c_y) and ($\tan \gamma$) respectively.

We shall assume that (r_0) = 0.

For the present we shall confine our attention to the expressions for the efficiency of two only of the types of blade considered.

"Rational" type of blade outline.

We have

$$\eta = \frac{P \int_{r_0}^r (2\pi x - P \tan \gamma) dx}{2\pi \int_{r_0}^r x^2 (P + 2\pi x \tan \gamma) dx} = \frac{P (4\pi r - 3P \tan \gamma)}{\pi r (4P + 6\pi r \tan \gamma)}$$

And now, if we write (Z) equal to the ratio of the effective pitch to the diameter of the air-screw, i.e. $\frac{P}{d}$, we obtain

$$\eta = \frac{2Z (2\pi - 3 \tan \gamma Z)}{\pi (4Z + 3\pi \tan \gamma)}$$

The substitution of (Z) for the ratio of pitch to diameter, $\frac{P}{d}$, puts the expression into a more convenient form.

Mr. A. R. Low has deduced practically the same expression for the efficiency of this type of blade, his formula being

$$\eta = \frac{1 - \frac{3M'}{2w}}{1 + \frac{3M''w}{4}}$$

where his (w) is equal to $\frac{\pi}{Z}$ (as used here), and his (M') and (M''), which are expressions for the average values of ($\tan \gamma$) over the blade, are equal to ($\tan \gamma$), supposed to be constant over the whole blade (as used here).

If we make these substitutions, the two expressions for the efficiency of this type of blade become identical.*

We can introduce a still further simplification into the "Rational" blade efficiency formula by taking the value of ($\tan \gamma$) as $1/12$. This is a very fair average value for the usual type of blade section employed in practice.

* See Paper on "Air-screws" read before the Aeronautical Society in April, 1918.

We have then

$$\eta = \frac{2.Z.(8\pi - Z)}{\pi.(16.Z + \pi)}$$

This curve may now be plotted against values of (Z). Such a curve is shown in Fig. (14).

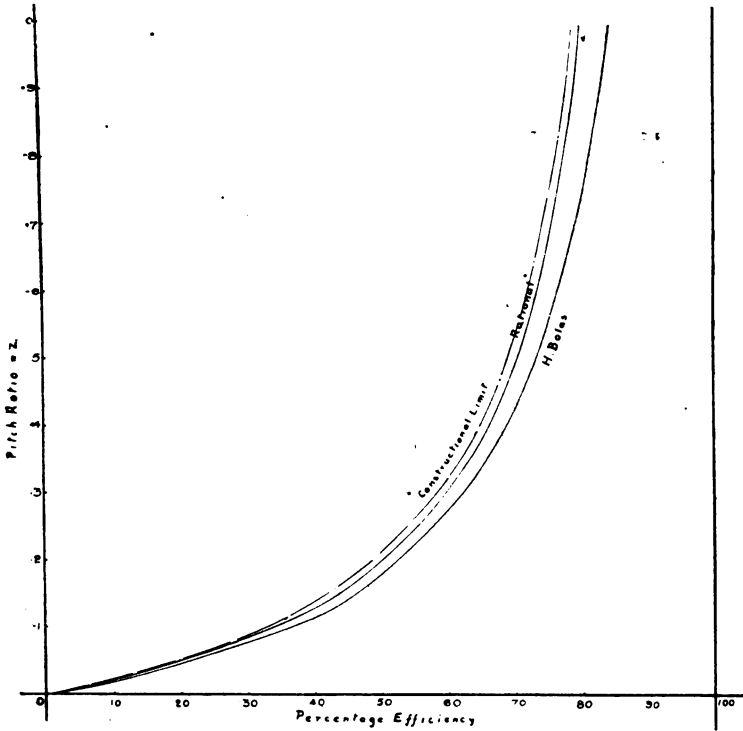

FIG. 14.

“Constructional Limit” type of blade outline.

We have

$$\eta = \frac{P \int_{r_0}^r (2.\pi.x - P. \tan \gamma) (P^2 + 4.\pi^2.x^2). dx}{2.\pi \int_{r_0}^r x.(P + 2.\pi.x. \tan \gamma) (P^2 + 4.\pi^2.x^2). dx}$$

$$= \frac{5.P.(6.\pi.P^2.d - 12.P^3. \tan \gamma + 3.\pi^3.d^3 - 4.\pi^2.P.d^2. \tan \gamma)}{\pi.d.(30.P^3 + 20.\pi.P^2.d. \tan \gamma + 15.\pi^2.d^2.P + 12.\pi^3.d^3. \tan \gamma)}$$

and now, as before, making the substitution $(Z) = \frac{P}{d}$, we obtain

$$\eta = \frac{5.Z.(6.\pi.Z^2 - 12.Z^3.\tan \gamma + 3.\pi^3 - 4.\pi^2.Z.\tan \gamma)}{\pi.(30.Z^3 + 20.\pi.Z^2.\tan \gamma + 15.\pi^2.Z + 12.\pi^3.\tan \gamma)}$$

And if we make $(\tan \gamma) = 1/12$, this reduces to

$$\eta = \frac{5.Z.(18.\pi.Z^2 - 3.Z^3 + 9.\pi^3 - \pi^2.Z)}{\pi.(90.Z^3 + 5.\pi.Z^2 + 45.\pi^2.Z + 3.\pi^3)}$$

and this curve may likewise be plotted against (Z) . The curve of this function is shown in Fig. (14).

It will be noticed from the two formulæ deduced for both the "Rational" and "Constructional Limit" efficiencies, that neither expression contains (d) , the diameter of the air-screw.

This is as might be expected, since (η) is non-dimensional, and hence the expression for the same should only involve ratios such as (Z) .

If we make $(\tan \gamma)$ equal constant, and therefore assume that (c_y) is constant over the blade, we may obtain quantitative expressions immediately evaluable for the case considered of the "Rational" blade shape. These are then as follows:—

$$N.T = \frac{c.\pi.n^2.\rho.c_y.P.d^2.(2.\pi.d - 3.P.\tan \gamma)}{12}$$

$$N.M = \frac{c.\pi.\rho.P.d^3.c_y.n^2.(4.P + 3.\pi.\tan \gamma.d)}{48}$$

and, since $(b) = \frac{2.c.P.\pi.x}{N.\sqrt{P^2 + 4.\pi^2.x^2}}$, we may obtain the above

expressions for the Thrust and Torque in terms of the width of the air-screw blade at the tip, i.e. when (x) is equal to (r) . We may denote this tip blade width by (b_r) .

These expressions then become

$$T = \frac{b_r.n^2.\rho.c_y.d.\sqrt{P^2 + \pi^2.d^2}.(2.\pi.d - 3.P.\tan \gamma)}{12}$$

$$M = \frac{b_r.\rho.c_y.n^2.d^2.(4.P + 3.\pi.\tan \gamma.d).\sqrt{P^2 + \pi^2.d^2}}{48}$$

and the value of (b_r), the width of the air-screw blade at the tip, is given by

$$b_r = \frac{c.P.\pi.d}{N.\sqrt{P^2 + \pi^2.d^2}}$$

In deciding upon the best form of blade outline for the air-screw, an ideal condition would appear to be obtained when the velocity in the slip stream is everywhere parallel to the axis and uniform, that is when the thrust at any radius is proportional to that radius. The ideal thrust grading diagram would thus be a straight line passing through the origin at the boss centre.

We can investigate the form of blade outline necessary to secure such a condition from the results already obtained in the general case.

It has already been shown that for any form of blade outline whatever, the thrust at any radius is given by

$$dT = c.\rho.n^2.f(x).\phi(x).(2.\pi.x - P.\psi(x)).\sqrt{P^2 + 4.\pi^2.x^2}. dx$$

and the condition specified is that

$$dT = m.x.dx,$$

whence

$$m.x = c.\rho.n^2.f(x).\phi(x).(2.\pi.x - P.\psi(x)).\sqrt{P^2 + 4.\pi^2.x^2},$$

and therefore

$$f(x) = \frac{m.x}{c.\rho.n^2.\phi(x).(2.\pi.x - P.\psi(x)).\sqrt{P^2 + 4.\pi^2.x^2}}$$

which gives the necessary form of blade outline to satisfy these conditions.

Whence it is only necessary to plot a curve of

$$\frac{x}{\phi(x).(2.\pi.x - P.\psi(x)).\sqrt{P^2 + 4.\pi^2.x^2}}$$

to obtain the required blade outline for any specified outside conditions.

It will be noticed that when (x) has the value of

$$\frac{P \cdot \psi(x)}{2 \cdot \pi},$$

that is at a distance of about one inch from the boss centre, the blade outline curve $f(x)$ becomes discontinuous, being of the form shown in Fig. (14A).

Thus in estimating the characteristics of such a type of

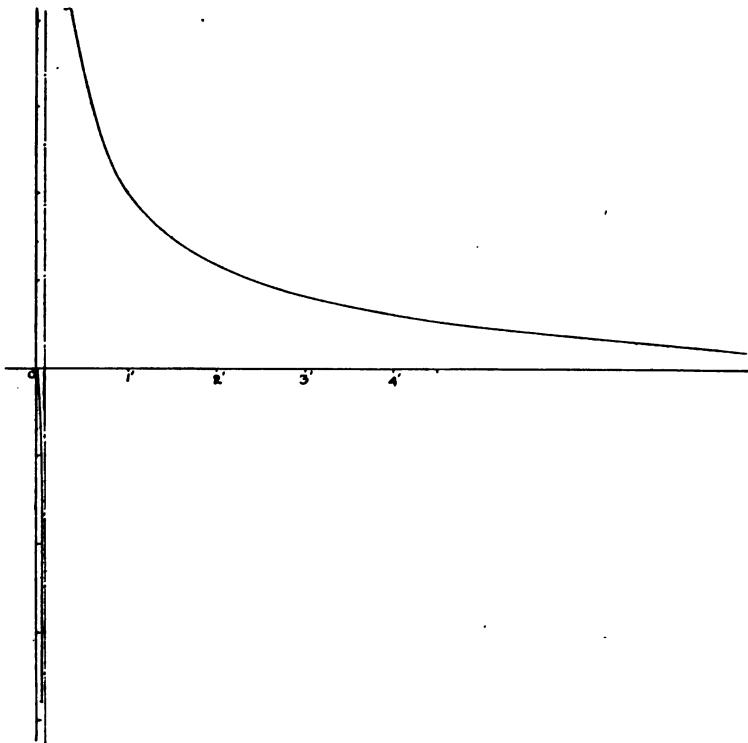

FIG. 14A.

blade it is impossible to integrate from the value $(r_0) = 0$, since the curve becomes discontinuous at the value $\frac{P \cdot \psi(x)}{2 \cdot \pi}$ of the radius.

It becomes necessary therefore, when evaluating the expressions characteristic of such a type of blade, to take for

the value of (r_0) a value greater than $\frac{P \cdot \psi(x)}{2 \cdot \pi}$. Since this value is usually very small, it will be sufficient to take for (r_0) a value of anything from say $(\frac{1}{10})$ to $(\frac{1}{5})$ of the length of each blade.

It is interesting to see how the efficiency of this type of blade compares with those types already investigated.

The efficiency of any type of blade is given by

$$\eta = \frac{P \cdot \int_{r_0}^r f(x) \cdot \phi(x) \cdot (2 \cdot \pi \cdot x - P \cdot \psi(x)) \cdot \sqrt{P^2 + 4 \cdot \pi^2 \cdot x^2} \cdot dx}{2 \cdot \pi \cdot \int_{r_0}^r x \cdot f(x) \cdot \phi(x) \cdot (P + 2 \cdot \pi \cdot x \cdot \psi(x)) \cdot \sqrt{P^2 + 4 \cdot \pi^2 \cdot x^2} \cdot dx}$$

and taking the value of

$$f(x) = \frac{m \cdot x}{c \cdot \rho \cdot n^2 \cdot \phi(x) \cdot (2 \cdot \pi \cdot x - P \cdot \psi(x)) \cdot \sqrt{P^2 + 4 \cdot \pi^2 \cdot x^2}}$$

we obtain

$$\eta = \frac{P \cdot \int_{r_0}^r x \cdot dx}{2 \cdot \pi \cdot \int_{r_0}^r \frac{x^2 \cdot (P + 2 \cdot \pi \cdot x \cdot \psi(x)) \cdot dx}{2 \cdot \pi \cdot x - P \cdot \psi(x)}}$$

and this becomes, after making the substitutions $\frac{P}{d} = (Z)$, and

$(r_0) = \frac{r}{10}$, and $\psi(x) = \tan \gamma = \text{constant}$,

$$\eta = \frac{3 \cdot \pi^2 \cdot Z}{2 \pi^3 \tan \gamma + 3 \pi^2 Z + 6 \pi \tan \gamma Z^2 + 6 \tan^2 \gamma Z^3 \log_e \left(\frac{10 \pi - 10 \tan \gamma Z}{\pi - 10 \tan \gamma Z} \right)}$$

and if $\tan \gamma = \frac{1}{12}$,

$$\eta = \frac{72 \cdot \pi^2 \cdot Z}{4 \cdot \pi^3 + 72 \cdot \pi^2 \cdot Z + 12 \cdot \pi \cdot Z^2 + Z^3 \cdot \log_e \left(\frac{60 \cdot \pi - 5 \cdot Z}{6 \cdot \pi - 5 \cdot Z} \right)}$$

It would appear that the curve of efficiency plotted against values of (Z) for this type of blade does not greatly differ from those already given. The efficiency for the respective values of (Z) is slightly higher than that obtained for the "Rational" blade under similar conditions of blade section and angles of attack.

CHAPTER IV.

BLADE SECTIONS, AND WORKING FORMULÆ.

IN air-screws manufactured for and used upon existing types of air-craft it will almost invariably be found that the blade section changes from the tip to the boss, and this is in fact a necessity, from considerations of strength due to the stresses in the blades caused by the thrust exerted by the air-screw and the centrifugal action due to the rotation of the whole air-screw about its axis at the boss centre.

Aerodynamically the use of a varying form of section along the blade usually somewhat tends to decrease the efficiency of the air-screw as a whole, although this probably does not amount to much. That is to say that the efficiency of any type of air-screw blade having a section varying from the boss to the tip is less than that of a blade of similar outline but having a uniform section throughout, provided that such a section is of such a form as to have a value of $(\tan \gamma)$ smaller than the average value of $(\tan \gamma)$ on the other blade, and equal to the smallest value of $(\tan \gamma)$ on any section there employed.

As a rule, for sections of similar shape, the thinner the section, i.e. the less the value of the $\frac{\text{thickness}}{\text{chord}}$ ratio, the lower the value of $(\tan \gamma)$, and hence the greater the overall efficiency of the whole blade employing such a section.

This only applies, however, between certain fairly well defined limits, for, after a certain value of the $\frac{\text{thickness}}{\text{chord}}$ ratio is reached, the section becomes less and less efficient, that is has a larger and larger value of $(\tan \gamma)$, until the limit is reached,

when the "camber" of the section altogether disappears and the section ultimately becomes a flat plate for which the value of the $\frac{\text{Lift}}{\text{Drag}}$ ratio is quite small, being of the order of (7) : (1) at the most efficient angle of incidence.

As a rule, in designing an air-screw to fulfil any given outside conditions, the forms of the blade sections are chosen

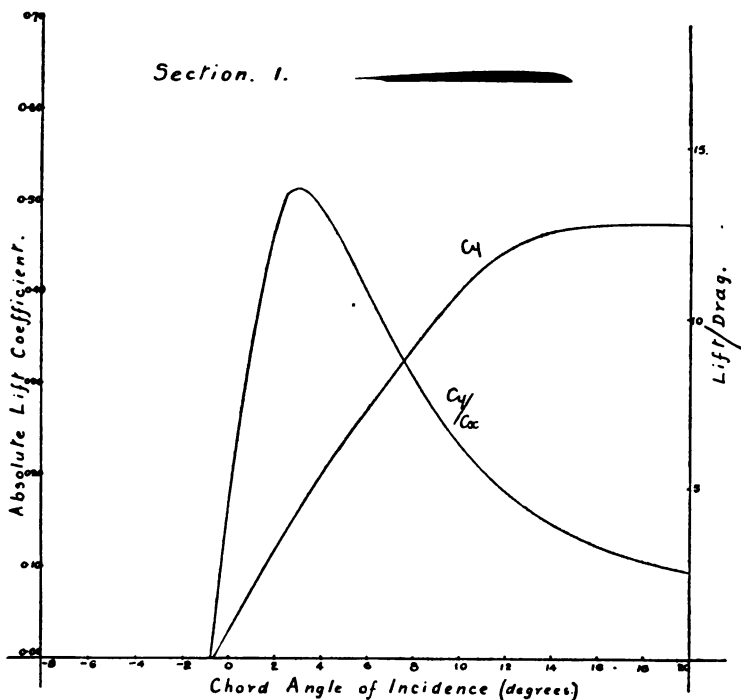

FIG. 15.

so as to effect as far as possible a compromise between considerations of aerodynamical efficiency and the necessary strength of the various portions of the blade.

The aerodynamical considerations of overall blade efficiency have, however, already been dealt with, and the expression for the efficiency of any type of blade shape put into a suitable form for purposes of air-screw design, so that we may proceed

to select our sections along the blade without stopping to consider whether it will be possible to express analytically the characteristics of the same in estimating the Thrust, Torque, and Efficiency of the whole blade, providing of course that the forms of the blade sections chosen are such that they conform to sections of which the characteristics are known from tests

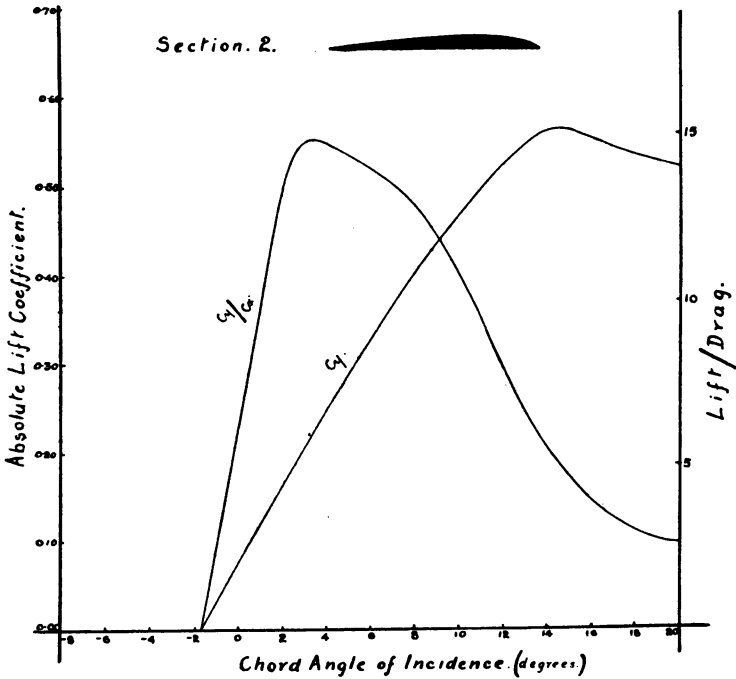

FIG. 16.

carried out in a wind-channel for the same when considered as aerofoils moving in a straight line.

A somewhat typical series of such sections are given in the "Technical Report of the Advisory Committee for Aeronautics for 1911-1912," and their characteristics are shown plotted in Figs. (15), (16), (17), (18), (19), (20), (21).

It will be noticed that the maximum value of the $\frac{\text{Lift}}{\text{Drag}}$

ratio, and hence the minimum value of $(\tan \gamma)$, occurs in all the sections at an angle of approximately (4) degrees.

We may of course use any "angle of attack" we please for each section along the blade, but it is advisable to use the angle corresponding to the least value of $(\tan \gamma)$ for each section considered, as this gives a better overall efficiency for the whole blade, since the efficiency of any section is equal to

$$\frac{\tan A}{\tan (A + \gamma)}$$

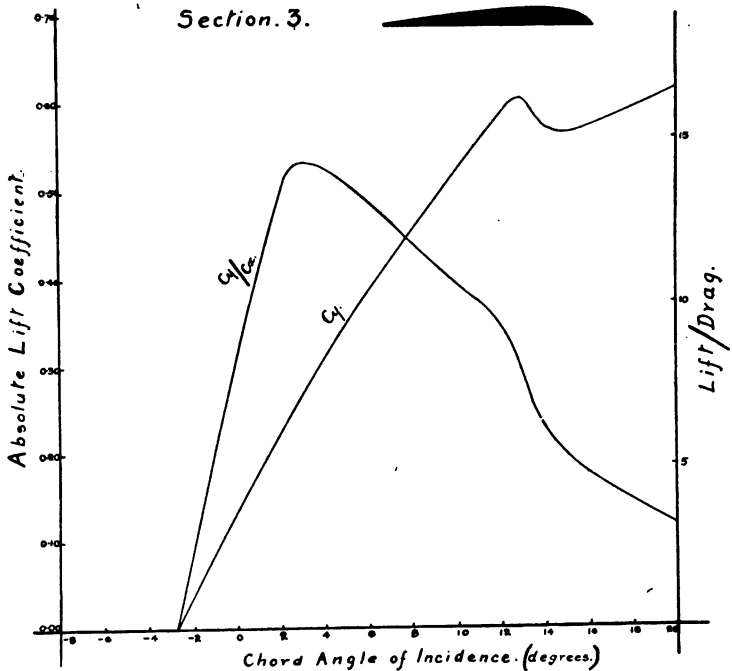

FIG. 17.

and hence the smaller the value of $(\tan \gamma)$, and hence of (γ) , the greater the efficiency at that section.

We now proceed then to a consideration of the design of any type of air-screw to fulfil any given specified set of conditions.

It is usual to start with the following data, which are supposed to be fixed from outside considerations.

- (1) (V) The horizontal velocity of the air-craft.
- (2) (n) The speed of revolution of the air-screw in revs./second.

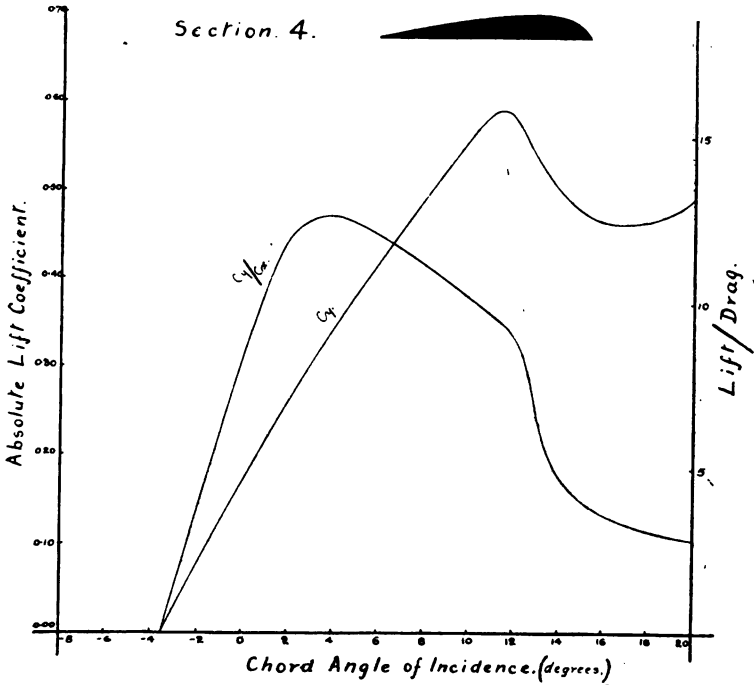

FIG. 18.

- (3) (d) The diameter of the air-screw. This is usually fixed from considerations of ground clearance, etc., and is usually made as large as the design of the air-craft will permit. This seems to be fairly standard practice at present. Experimental research is required before this point can be definitely settled.

- (4) $\phi(x)$ and $\psi(x)$ These functions of (c_y) and $(\tan \gamma)$ depend upon the form of the sections employed at various radii along the blade and their respective "angles of attack," and may be plotted when the form and position of these relative to the boss centre are known.

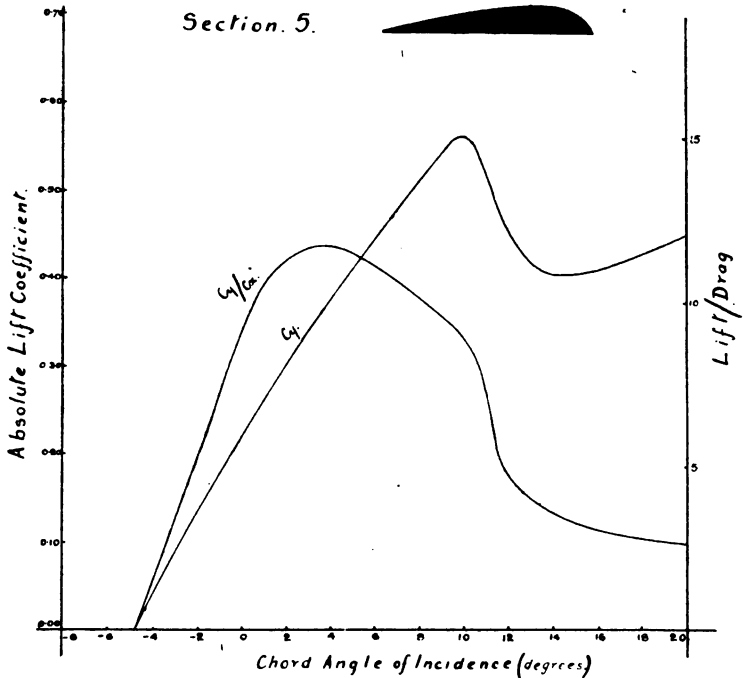

FIG. 19.

- (5) (H) The B.H.P. of the motor multiplied by the efficiency of the transmission (if any) supplied to each air-screw (if there are more than one).

We now proceed to draw out the blade shape of the air-screw, making ordinates on the curve represent proportional

widths. Here experience and a study of the particular type of air-craft to which the air-screw is to be fitted will guide us.

Portions of the air-craft coming within the air-screw's disc of revolution must be taken into account when designing the blade shape.

An air-screw fitted to a rotary motor having a large cowl, for instance, will not probably require so large a blade width

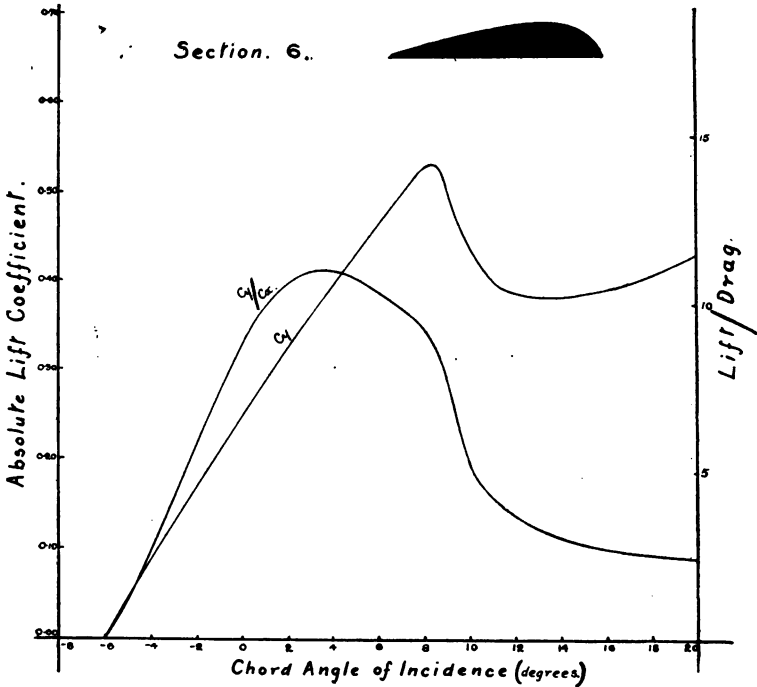

FIG. 20.

for best efficiency at the inside radii near the boss as would otherwise be advisable if the air-screw were working free from any such obstructions in the air-flow.

In the theory of air-screw design as set forth in this book no quantitative notice is taken of such stationary parts of the air-craft, and to do so would be in most cases an exceedingly difficult problem.

A study of the efficiency curve for the blade will also help us in the designing of a suitable blade outline.

Bearing then these considerations in mind we commence the designing of our air-screw as follows:—

- (1) Plot the efficiency curve

$$\frac{P \cdot (2\pi \cdot x - P \cdot \psi(x))}{2\pi \cdot x \cdot (P + 2\pi \cdot x \cdot \psi(x))}$$

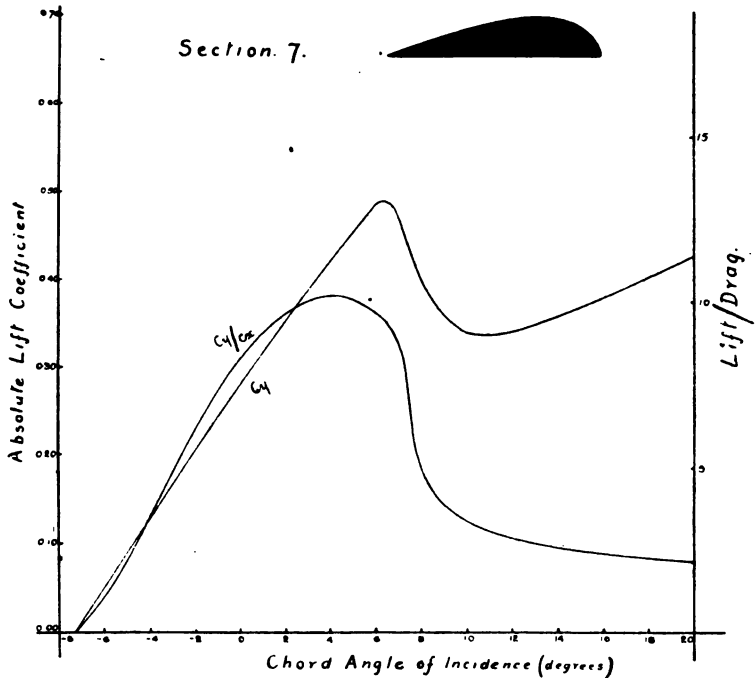

FIG. 21.

We do not as yet know the value of the function $\psi(x)$, but for a first approximation we may take this as being constant and equal to say $\frac{1}{12}$.

In slow running air-screws this curve of blade efficiency will be found to be almost a parallel line with the (x) axis, except close up to the boss, where it runs down to the origin very rapidly.

In high speed air-screws the change in slope of the efficiency curve will be more marked, and this brings us to a consideration of the best blade shape under these conditions.

As an example of a good blade outline for an air-screw, the four-bladed air-screw as used on the Royal Aircraft Factory aeroplanes may be cited. This screw revolves at a speed of 900 r.p.m., which is if anything rather on the slow side.

We may however take it as a fairly good general rule that in designing an air-screw blade, the maximum ordinate on the blade outline curve, that is the point where the blade is widest, should be somewhat nearer the tip of the blade than the point of maximum efficiency as given by the efficiency curve.*

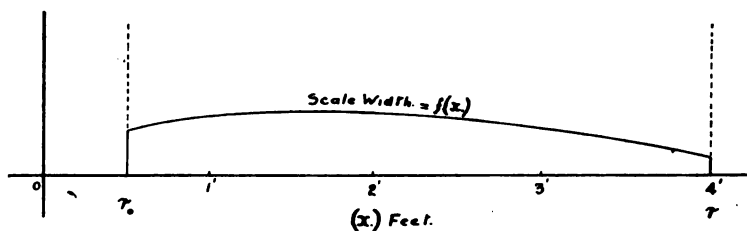

FIG. 22.

It is not proposed here to discuss the theoretically best form for the blade outline function $f(x)$, as to do so would be a very difficult matter when treated generally.† Experience is a good guide in choosing a suitable shape for the form of this function.

Taking then the blade outline as being something of the

* Recent tests on aerofoils with elliptical-shaped ends have shown a marked improvement, in $\frac{\text{Lift}}{\text{Drag}}$ ratio, over similar aerofoils with square-cut ends, provided that the section of blade in the former case is everywhere geometrically similar. This indicates the superiority, from efficiency point of view, of blades with tapered tips, apart from any other considerations.

† A general treatment of the variation in (η) due to variation of $f(x)$, and the determination of the form of $f(x)$ giving to (η) a maximum value, would require the application of the Calculus of Variations, and is beyond the scope of the present work.

form shown in Fig. (22), we may proceed to the determination of the complete design of the air-screw.

(2) It is first necessary to fix the $\frac{\text{thickness}}{\text{chord}}$ ratios of the sections along the blade, and here again practical experience will help us. It is undesirable to make the blade sections too thin, especially near the boss, as this leads to undue flexibility in the blade, with corresponding losses in efficiency.

In an air-screw having a diameter of (8) or (9) feet, the following proportioning of the sections along the blade would seem to be fairly standard practice:—

At a radius of (1) foot from the boss centre,	Section No. 7, Fig.(21).
„ „ (2) feet „ „ „ „	„ 6, Fig.(20).
„ „ (3) „ „ „ „	„ 5, Fig.(19).
„ „ (4) „ „ „ „	„ 4, Fig.(18).

Having then selected a suitable series of aerofoil sections and having spaced them along the blade, we may proceed to the determination of the two functions $\phi(x)$ and $\psi(x)$ characteristic of such sections.

The respective “angles of attack” of the various sections employed will of course be the angles corresponding to the least value of $(\tan \gamma)$ in each case, since this will give the highest efficiency for any specified spacing of the sections and form of blade outline.

In the case considered, these “angles of attack” are taken as being constant and equal to (4) degrees, since, as already stated, and as a reference to the curves given in Figs. (18, 19, 20, 21) will show, the respective minimum values of $(\tan \gamma)$ occur approximately at the same angle of incidence in each case, namely (4) degrees.

In this connection it does not seem to be unreasonable to assume that sections lying between any two selected sections along the blade will have characteristics intermediate between those of the two respective outside sections considered, and

quantitatively will approximate to the values of the characteristics shown on a smooth curve drawn between the various points along the blade corresponding to the characteristics of the selected sections at those points.

We shall then obtain a series of points for the values of (c_y) and ($\tan \gamma$) for the various radii chosen, and if smooth curves be drawn through these points we shall obtain the two curves denoted by $\phi(x)$ and $\psi(x)$.

Fig. (23) gives these two curves for the sections and spacing of the sections considered and for a uniform "angle of attack" of (4) degrees.

We are now able to read off from the two graphs plotted of $\phi(x)$ and $\psi(x)$ the respective values of these two functions for any value of (x) considered, that is for any point along the blade.

(3) It now only remains to determine the true value of the blade width for every point along the blade.

The efficiency of the whole blade can be found at once, since we know the values of the two functions $\phi(x)$ and $\psi(x)$ for each value of (x) considered.

The value of (b), the true blade width at any radius (x), can be obtained in the following manner.

We already know that

$$b = c.f(x),$$

where $f(x)$ denotes the scale blade width for each value of (x) considered, and the value of $f(x)$ is thus the value of the ordinate on the curve of proportional blade widths already drawn. So that we have only to find the value of (c) in order to be able to completely determine the value of (b) for any value of the radius (x).

It has already been shown that the Torque (M) of each blade of the air-screw may be expressed as

$$M = c.\rho.n^2. \int_{r_0}^r f(x). \phi(x). (P + 2.\pi.x. \psi(x)). \sqrt{P^2 + 4.\pi^2.x^2}. dx.$$

And further ($N.M.2.\pi.n$) is proportional to the horse-power

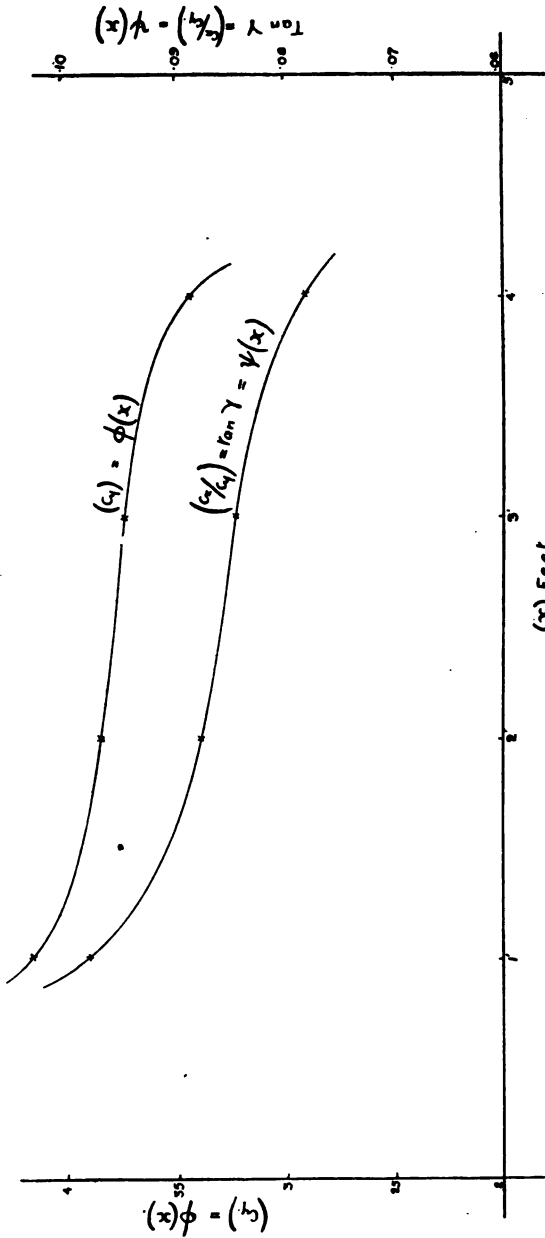

FIG. 28.

available to turn the whole air-screw, where (N) denotes the number of blades.

Hence if we use lb./ft./sec. units we get that

$$\frac{N.M.2.\pi.n}{550} = H,$$

where (H) is the available B.H.P. after allowing for losses in transmission (if any transmission is employed).

We also have the value of (ρ) as being equal to (.00238) in lb./ft./sec. units.

So that we can at once write

$$\frac{2.\pi.n^3.N}{550}.c.\rho.\int_{r_0}^r x.f(x).\phi(x).(P+2.\pi.x.\psi(x))\sqrt{P^2+4.\pi^2.x^2}.dx = H,$$

whence

$$c = \frac{550.H}{2.\pi.n^3.N.\rho.\int_{r_0}^r x.f(x).\phi(x).(P+2.\pi.x.\psi(x))\sqrt{P^2+4.\pi^2.x^2}.dx},$$

and this gives the necessary value of (c) for any given outside conditions.

It will be noted that all dimensions must now be measured in feet.

We proceed then to the evaluation of the blade width constant (c).

Since we have not obtained the functions $\phi(x)$ and $\psi(x)$ in an algebraic form, that is we do not know the equations to these two curves, we cannot evaluate the definite integral

$$\int_{r_0}^r x.f(x).\phi(x).(P+2.\pi.x.\psi(x))\sqrt{P^2+4.\pi^2.x^2}.dx$$

algebraically, and hence must employ a graphical method throughout. This also applies to the evaluation of (η), the efficiency of the whole blade.

In order then to obtain the value of (c) it is first

necessary to determine graphically the value of the definite integral

$$\int_{r_0}^r x \cdot f(x) \cdot \phi(x) \cdot (P + 2\pi \cdot x \cdot \psi(x)) \cdot \sqrt{P^2 + 4\pi^2 \cdot x^2} \cdot dx,$$

and we may proceed to do this as follows.

Plot the graph of the function

$$x \cdot f(x) \cdot \phi(x) \cdot (P + 2\pi \cdot x \cdot \psi(x)) \cdot \sqrt{P^2 + 4\pi^2 \cdot x^2}$$

to some convenient scale against values of (x), the radius from the boss centre in feet.

We already know the value of (P); it is $\frac{V}{n}$; and both (V) and (n) are known to start with, since they are assumed to be fixed from outside considerations.

The value of $f(x)$ for any radius (x) is known, since it is the value of the ordinate on the scale blade width already drawn. The value of $f(x)$ is to be measured in feet, that is to say we must take some convenient scale on the graph paper to represent so many inches equal to one foot.

The respective values of $\phi(x)$ and $\psi(x)$ are determined at once from a reference to the two curves already plotted of these functions for any value of (x).

• Having then taken a sufficient number of values of (x), and having determined the corresponding values of the function the graph of which we are plotting, a smooth curve drawn through the points so obtained will give the curve required.

Now draw two ordinates from the (x) axis at the points (r_0) and (r) respectively until same cut the curve just plotted.

Then the area of the enclosed figure so obtained, that is the figure contained by the curve, the two extreme ordinates at (r_0) and (r), and the (x) axis, is the value of the definite integral required.

The areas of closed figures of this kind are most easily obtained by means of a planimeter.

It is to be noted here in this connection that the actual area of the figure so obtained will be in, say, square inches, and

hence that it must be multiplied by some constant in order to find the real value of the definite integral.

The value of this constant will depend, of course, upon the scale employed in the plotting of the graph.

Thus, if the ordinate on the curve corresponding to any value of (x) has a value obtained from the formula

$$x f(x) \cdot \phi(x) \cdot (P + 2 \cdot \pi \cdot x \cdot \psi(x)) \cdot \sqrt{P^2 + 4 \cdot \pi^2 \cdot x^2}$$

of such and such an amount, this value will probably not be able to be represented on the graph paper used, since it may be very much too large when taken to the same scale as that of the (x) axis, and hence the scale of "heights" or ordinates will probably have to be made much smaller than the scale used for the (x) axis.

Having then obtained the value of this area in the required dimensions, we may determine the value of (c) at once.

It is given by

$$c = \frac{550 \cdot H}{2 \cdot \pi \cdot n^3 \cdot N \cdot \rho \cdot (\text{area of figure obtained})}$$

where (ρ) has the value of $(\cdot 00238)$ as already given.

We have then that the true or necessary blade width at each radius (x) is the value of the scale blade width at that radius multiplied by the value of the constant (c) already found.

Or

$$b = c f(x).$$

The value of $f(x)$ for any radius (x) will, of course, be measured off the curve of this function already drawn, and its corresponding real value found by reference to the scale employed in drawing the curve.

Thus, if 1 inch on the curve ordinate represents 1 foot as the actual scale blade width, a value measured at any radius of, say, $(\cdot 75)$ inch as the ordinate of the curve at that radius would represent an actual scale blade width of $(\cdot 75)$ foot, that is (9) inches.

And further, if the value of (c) was found to be, say, $(1 \cdot 2)$, then the true or actual blade width at this point would be

equal to (9×1.2) inches, that is (10.8) inches. And this would be the width of the blade at that radius to be used in the construction of the air-screw.

We may obtain the value of the total efficiency of each blade, and hence of the whole air-screw, in a similar manner as follows.

Plot the two curves

$$f(x) \cdot \phi(x) \cdot (2 \cdot \pi \cdot x - P \cdot \psi(x)) \cdot \sqrt{P^2 + 4 \cdot \pi^2 \cdot x^2} \dots \dots (1)$$

and

$$x \cdot f(x) \cdot \phi(x) \cdot (P + 2 \cdot \pi \cdot x \cdot \psi(x)) \cdot \sqrt{P^2 + 4 \cdot \pi^2 \cdot x^2} \dots \dots (2),$$

which is the one already plotted, and which therefore it is unnecessary to replot.

Take the area of the figure enclosed by (1), the extreme ordinates at (r_0) and (r) , and the axis of (x) .

The area enclosed by (2) has already been obtained from the evaluation of (c).

Divide the area enclosed by (1) by the area enclosed by (2), and multiply the result by $\frac{P}{2 \cdot \pi}$. The answer will be the efficiency of the air-screw.

It will not, of course, be necessary to trouble about scale constants, etc., in determining the value of the efficiency of the whole blade, as, provided that the two graphs (1) and (2) are drawn to the same scale, it will only be necessary to divide their actual areas one by the other in whatever dimensions these two areas are obtained, provided, of course, that each area is measured in the same dimensions.

In the determination of (c), and hence of the real blade width for each radius, it will usually be found that the true blade widths for each point along the blade will be somewhat smaller than those actually employed in practice on a similar form of air-screw. This is due to the fact that the calculated Torque (M) is higher than the actual Torque found in practice, and hence that the necessary blade widths at each radius will have to be larger than those given by the theory.

Of course no one for a moment supposes that the theory of

air-screw design based on an analogy with aerofoils moving in a straight line is absolutely exact. It is merely a very useful theory, the results of which conform very closely with those actually obtained by experiment.

It is difficult to estimate the amount of this difference between the calculated and actual Torques, without actual quantitative experimental results, but it would appear that the actual value of (c) is between $\frac{100}{75}$ and $\frac{100}{78}$ times the calculated value as given by the theory.

So that after having obtained the calculated value of (c) , it will be prudent to augment this value by say 33%, that is multiply the value of (c) obtained from the formula by $\frac{100}{75}$.

It will be useful here to have some independent check upon the working, so that any arithmetical slips in the evaluation of quantities such as (c) may be as far as possible avoided.

We may obtain a rather approximate check of this kind by reference to the "Rational" blade outline form already considered.

If, in the expressions deduced for the characteristics of this form of blade, we assume that both (c_y) and $(\tan \gamma)$ are constant over the blade, and that (r_0) is equal to zero, and further if we take the value of $(\tan \gamma)$ to be $\frac{1}{12}$, then we obtain the following expression for the necessary blade width constant (c) .

$$c = \frac{52800. H}{\pi^2.n^3.P.\rho.c_y.d^3. (16.P + \pi.d)},$$

and since as already shown

$$c = \frac{b_r.N.\sqrt{P^2 + \pi^2.d^2}}{P.\pi.d},$$

where (b_r) denotes the tip blade width, we can obtain the necessary value of (b_r) by substitution, thus

$$b_r = \frac{52800. H}{\pi.n^3.\rho.c_y.d^2.N. (16.P + \pi.d).\sqrt{P^2 + \pi^2.d^2}}.$$

And this then provides a useful approximate check upon

the previous work in the determination of the true blade width for each radius (x).

It will be noticed from this and previous expressions for blade width, that doubling the number of blades of an air-screw merely halves the respective widths of same at corresponding radii.

This theory does not in fact take any notice of possible improved efficiency by the use of more than the customary two blades for an air-screw.*

We may also obtain an approximate value for the efficiency of the whole blade by means of the same "Rational" form of blade outline.

This has already been shown to be given by

$$\eta = \frac{2.Z. (2.\pi - 3. \tan \gamma. Z)}{\pi. (4.Z + 3.\pi. \tan \gamma)},$$

which reduces to the simpler form

$$\eta = \frac{2.Z. (8.\pi - Z)}{\pi. (\pi + 16.Z)}$$

when $(\tan \gamma)$ has the value of $\frac{1}{12}$.

Now there will be, corresponding to some particular value of (Z) , a value of (η) which will be a maximum, and this will therefore give the theoretically best value of (Z) and therefore of (n) to use for any given set of conditions, since the values of (V) and (d) will usually be fixed from outside considerations.

We may obtain the value of this maximum efficiency and the value of (Z) for which it is a maximum as follows.

The condition for a maximum value of (η) is

$$\frac{d\eta}{dZ} = 0,$$

and this gives

$$Z_1 = \frac{\pi}{4} \cdot [\sqrt{8 + 9. \tan^2 \gamma} - 3. \tan \gamma],$$

giving the requisite value of (Z) for a maximum value of (η) .

* Except in so far as the greater the number of blades employed the higher the aspect ratio of each, and hence the greater the efficiency of the air-screw due to increase of aspect ratio.

This expression is seen to approximate to the value $\frac{\pi \cdot \sqrt{2}}{2}$ as $(\tan \gamma)$ approaches zero.

As a rule this value is in the neighbourhood of (2) and hence we may say that, for a near approximation, (η) has a maximum value when (Z) is equal to (2).

Now $(Z) = \frac{P}{d} = \frac{V}{n \cdot d}$, and hence if (V) and (d) are fixed by outside considerations, the value of (n) for which the efficiency of the air-screw is a maximum is given by

$$Z_1 = \frac{V}{n_1 \cdot d} = 2,$$

whence

$$(n_1) = \frac{V}{2 \cdot d} \text{ revs./sec.}$$

So that if

$$\begin{aligned} (V) &= 100 \text{ feet/sec.}, \\ (d) &= 10 \text{ feet,} \end{aligned}$$

the speed at which the air-screw, or air-screws, should be run in order to obtain the maximum efficiency would be (5) revs./sec., that is (300) revs./min.

This speed is of course abnormally slow in the light of present-day practice, although the speed of revolution of the air-screws in some of the Wright aeroplanes is as slow as (450) revs./min.

A curve of efficiency for values of the $\frac{\text{Pitch}}{\text{Diameter}}$ ratio (Z) has already been given for values of (Z) occurring in practice.

Mr. H. Bolas gives a formula for the efficiency of an air-screw of good shape * (*see* "Technical Report of the Advisory

* This formula is only an approximate one. It is

$$\begin{aligned} \eta &= \frac{1}{1 + k \cdot \tan \gamma \cdot \cot \theta} \\ &= \frac{Z}{Z + \pi \cdot k \cdot \tan \gamma}, \end{aligned}$$

and if $\tan \gamma = \frac{1}{12}$, $k = \cdot 7$, we get

$$\eta = \frac{Z}{Z + \cdot 183},$$

which may then be plotted against (Z) .

Committee for Aeronautics, 1911-12"), and this has also been plotted against values of (Z) . The two curves of efficiency are shown in Fig. (14), and their close general resemblance will be noticed.

It would seem that at any rate to a first approximation the efficiency of almost any modern type of air-screw may be obtained from the formula or graph given for the "Rational" shape.

As a rule, in practice it is found that the actual recorded efficiencies of air-screws are higher than those given by the theory.

Since (Z) may be taken as equal to (2) for a maximum value of (η) , the maximum value of (η) will be obtained by substituting this value for (Z) in the efficiency formula. We shall take $(\tan \gamma)$ as being equal to $\frac{1}{12}$ as before, and then we have the value of (η) as $(.84)$. Hence the maximum overall efficiency of an air-screw having a "Rational" blade shape is (84%) when $(\tan \gamma) = \frac{1}{12}$ and $(Z) = (2)$.

Suppose that we wish to design an air-screw for an aeroplane having a speed (V) of (100) feet/sec., a rotational speed (n) of (20) revs./sec., a diameter (d) of (9) feet, and having a motor capable of developing an effective horse-power (H) of (100) .

Then

$$\left. \begin{array}{l} (V) = 100 \\ (n) = 20 \\ (d) = 9 \\ (H) = 100 \end{array} \right\} \text{and hence } (P) = \frac{V}{n} = 5 \text{ feet.}$$

Let the spacing of the sections along the blade be such as already given with a uniform "angle of attack" of (4°) , and hence let the curves of $\phi(x)$ and $\psi(x)$ be such as given in Fig. (23).

Suppose that the form of $f(x)$, the blade outline, is that given in Fig. (22).

Then we have to determine (1) The actual blade widths at every point along the blade.

(2) The total efficiency of the whole air-screw.

We shall neglect the B.H.P. consumed in turning the portion of the air-screw from the boss centre to the inside radius (r_0), as by doing so we shall be on the safe side, since our blade widths will now tend to come out larger than if we allowed for the B.H.P. used near the boss. In any case the amount of this B.H.P. is very small.

We proceed to determine the value of (c) in the manner given by plotting the graph of

$$x \cdot f(x) \cdot \phi(x) \cdot (P + 2\pi \cdot x \cdot \psi(x)) \cdot \sqrt{P^2 + 4\pi^2 \cdot x^2},$$

taking values of $f(x)$, $\phi(x)$, and $\psi(x)$ from the curves already plotted of these functions.

The graph is shown in Fig. (24), and the actual area (as originally drawn) is (50·25) sq. ins., between the two extreme radii.

Now the scale of ordinates for this curve is taken to be for convenience $\frac{1}{8}$ of the horizontal scale, so that the true area enclosed by the curve will be ($8 \times 50\cdot25$) sq. ins., and, since the horizontal scale employed is (2) ins. equal to one foot, this area corresponds to (100·5) sq. feet.

Hence, applying the formula for (c), we get

$$c = \frac{550 \cdot H}{2\pi \cdot n^3 \cdot N \cdot \rho \cdot (\text{Area of figure})} = 2\cdot3,$$

where (N) = (2). It will be noticed that if we employ (4) blades instead of (2), the value of (c), and hence the value of the blade width at any radius, is halved.

If we now multiply the value (2·3) for (c) obtained above by say $\frac{100}{75}$, so as to allow for differences between the

calculated and actual Torques, we obtain (3.07) as a more exact value for this constant.

We can now of course obtain the true blade widths at each radius by multiplying their respective values as given on the

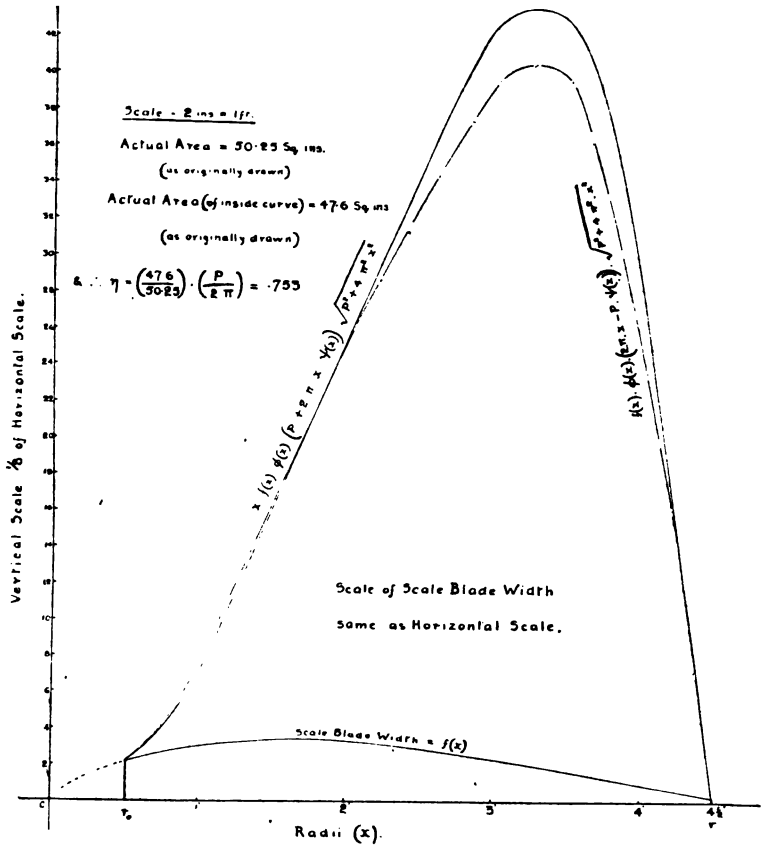

FIG. 24.

scale blade width curve by (3.07) when the air-screw has (2) blades.

We can also check this value by applying the "Rational" blade constant formula and this then gives

$$b_r = \frac{52800 \cdot H}{\pi \cdot n^3 \cdot \rho \cdot c_y \cdot d^2 \cdot N \cdot (16 \cdot P + \pi \cdot d) \cdot \sqrt{P^2 + \pi^2 \cdot d^2}}$$

= (.486) foot, which is the value of the width of the blade at the tip, when $(N) = (2)$. The value of (c_y) has been taken to be (.36). This value of the blade tip width is about what might be expected for this type of blade, where the blade increases in width towards the tip.

We may now determine the value of (η) , the total efficiency of the whole blade. We plot the curve

$$f(x). \phi(x). (2.\pi.x - P. \psi(x)). \sqrt{P^2 + 4.\pi^2.x^2},$$

and take the area of the figure enclosed by it, the two extreme radii at (r_0) and (r) , and the (x) axis.

The area of this curve as originally drawn is approximately (47.6) sq. ins. Fig. (24).

The value of the total efficiency of the whole blade is then equal to

$$\left(\frac{47.6}{50.25}\right) \cdot \left(\frac{P}{2.\pi}\right) = \left(\frac{47.6}{50.25}\right) \cdot \left(\frac{5}{2.\pi}\right) = .753,$$

since (P) is equal to (5) feet.

The efficiency of an air-screw of this type would therefore be approximately 75.3%.

The blade sections of an air-screw at the inside radii near the boss have to be made thick from considerations of strength. We may, however, choose suitable shapes for the outside radii from sections which have a high value of the $\frac{\text{Lift}}{\text{Drag}}$ ratio as aerofoils.

A few typical examples of such suitable shapes are given in Figs. (25), (26), (27), (28).*

* See "Technical Report of the Advisory Committee for Aeronautics, 1912-18."

AIR-SCREWS

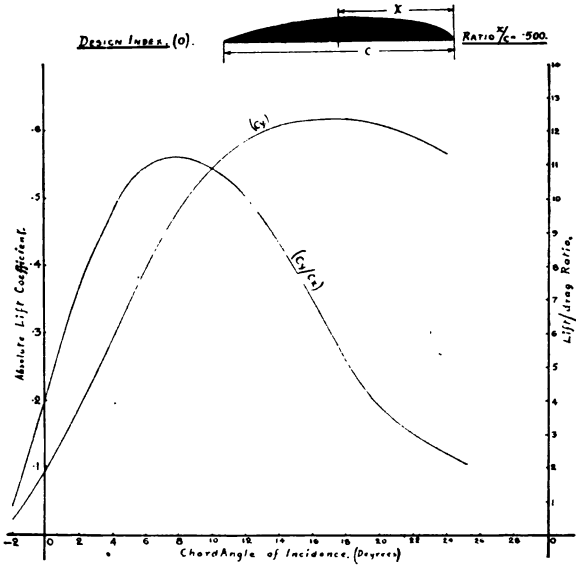

FIG. 25.

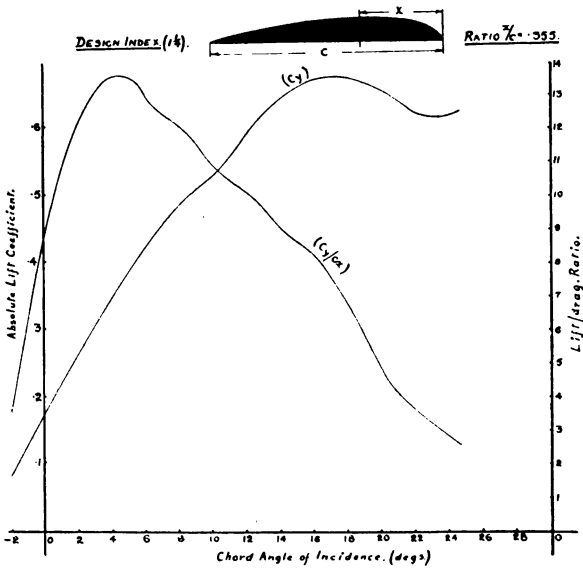

FIG. 26.

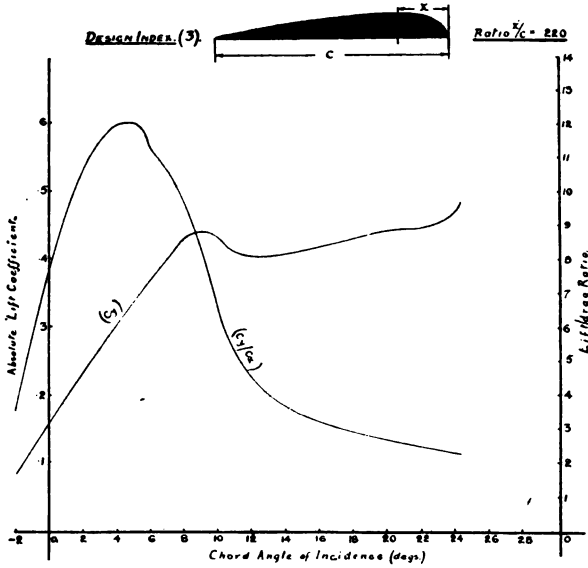

FIG. 27.

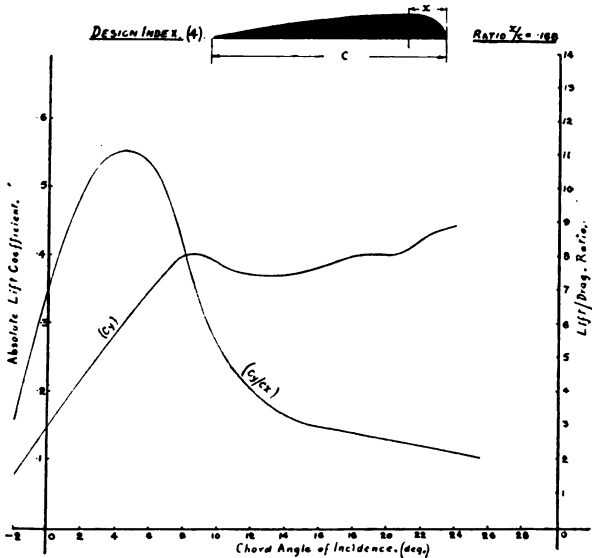

FIG. 28.

CHAPTER V.

"LAYING OUT" THE AIR-SCREW.

IN commencing to lay out the blade sections of an air-screw, it is first necessary to determine the chord angles of the blade at several radii. Having done this, the plan and elevation of the blade may be drawn out, consideration being given to the fact that as far as possible the two following conditions should be satisfied :—

- (1) The centre of area of the sections should lie on the blade axis.
- (2) The respective positions of the centres of pressure of the sections should be so arranged about the blade axis as to eliminate as far as possible all twist on the blade. The loading on the blade may be taken as being uniplanar.

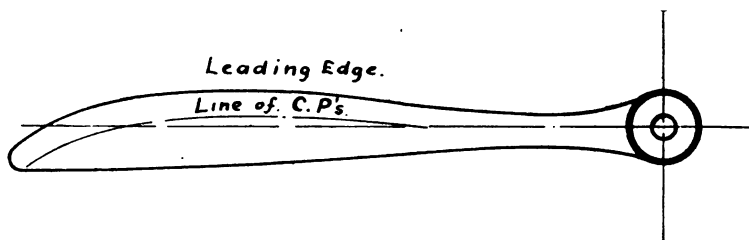

FIG. 29.

These two conditions may be occasionally somewhat antagonistic.

A symmetrical plan form is undesirable. A good plan form is shown in Fig. (29).

We can obtain the true chord angles (ϕ) for each radius along the blade considered from the relation

$$\phi_x = \alpha_x + \tan^{-1} \left(\frac{P}{2.\pi.x} \right),$$

where (P) has the value of $\frac{V}{n}$ as already defined.

The values of (α_x) may vary along the blade, although usually it will be found that the values of the “angles of attack” are approximately constant and in the neighbourhood of 4 degrees.

If we draw, Fig (30), a vertical line to represent the value of $\frac{V}{n}$ and a horizontal line to represent (radii $\times 2.\pi$) in the same units, we may, by drawing in the various hypotenuses, obtain the inclination of the helix paths for any element along the blade. And if these helix angles (A) be augmented by the respective “angles of attack” at these points, we shall obtain the true chord angles for the various radii considered.

If, further, the widths of the blade at these radii be drawn in to scale along the chord angle lines, we may at once proceed to lay out the plan and elevation of the whole blade.*

Sections near the boss may be thickened up if necessary by adding a convex lower surface. In such sections the calculated chord angles may have to be departed from. This is not of great importance, although the actual chord angles of such sections should not be less than their respective helix angles at these radii.

Modern air-screw blades are built up of several separate laminations of wood. French walnut is usually chosen as the most suitable material from which to construct the air-screw.

The laminæ may be easily laid out when the chord angles

* Strictly the blade widths and sections at each radius when obtained should lie on cylindrical sections coaxial with the air-screw, and not on plane sections at right angles to a fixed arbitrary line in the blade. The difference, however, is small at all but the smallest radii, where it is of least importance.

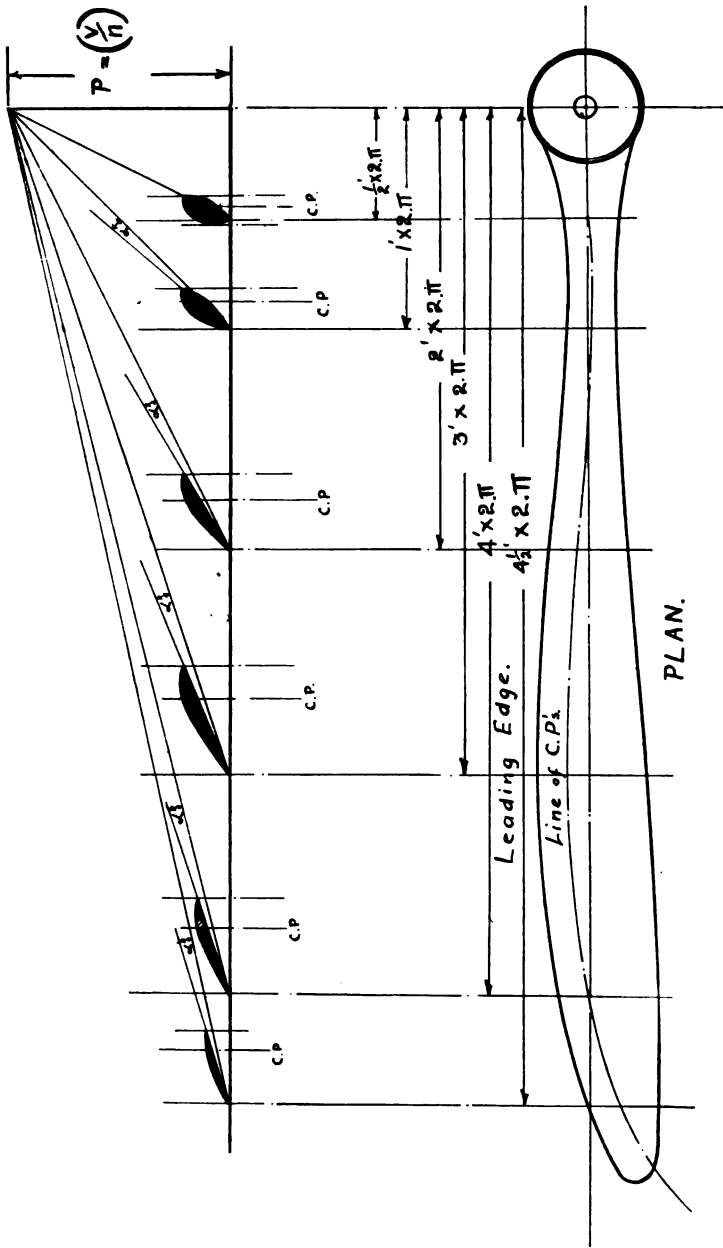

Fig. 90.

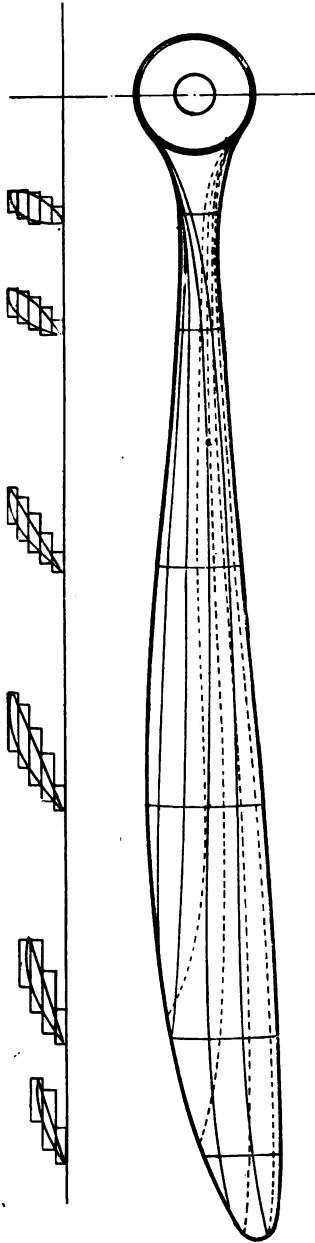
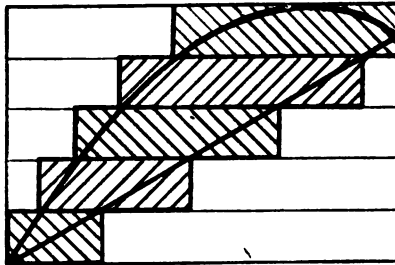

FIG. 32.

at the several radii considered have been determined. The method is indicated in Fig. (31).

The plotting of the contours along the blade is obtained from a consideration of the plan form of blade and the construction of the laminae. A specimen contour plotting is shown in Fig. (32).

In the laying out of the air-screw the various curves should as far as possible be run into the boss with smooth curves, the



! FIG. 31.

size of the boss being fixed from considerations of blade width and type of air-screw mounting used.

The thickening up of blade sections by means of a convex under surface would not appear to affect their aerodynamic properties to any great extent. Such thickening up may sometimes be necessary from considerations of strength.*

* The employment of a convex undersurface appears to slightly decrease the value of (c_p) , and hence necessitates the utilisation of a wider blade section. This is sometimes done when a stronger section is required. The $\frac{\text{Lift}}{\text{Drag}}$ ratio is only very slightly affected.

CHAPTER VI.

STRESSES IN AIR-SCREW BLADES.

Centrifugal Stresses.

WHEN an air-screw is rotating about its axis at the boss centre, the various elements which go to make up each blade are forced to follow a circular path. The forces necessary to make these portions of the blade follow such circular paths are directed towards the point about which the air-screw is rotating (i.e. the boss centre), and are of amount equal to

(weight of portion of blade considered) . (average velocity of portion considered)² divided by (g) . (average distance of portion from the boss centre).

Hence the reactionary forces with which the portions of the blade "pull" on any section considered are of the same amount, and constitute a stress in the material of which the blades of the air-screw are made.

Let Fig. (33) represent a blade of an air-screw, and let AA' be a section of same at a radius of (X) feet from the boss centre. Then the centrifugal stress on the section AA' is composed of the "total pull" exerted by the portion of the blade from AA' to the tip, divided by the area of the section at AA'.

Let (r) denote the overall length of each blade in feet. And consider the portion of the blade from AA' to the blade tip of length $(r-X)$ feet.

Consider the centrifugal pull on AA' due to a small element of the blade cut off by the two radii (x) and $(x + dx)$ respectively. Then (X) remains constant, while (x) varies from the value (X) to the value (r) .

Then centrifugal pull on AA' due to the element considered may be written

$$dF = \frac{(\text{weight of element})}{g} \cdot \frac{(\text{velocity of element})^2}{x}$$

And let (w) = weight in lbs. of one cubic foot of the material of which the blades of the air-screw are made, and (w) is then assumed to remain constant for all values of (x) .

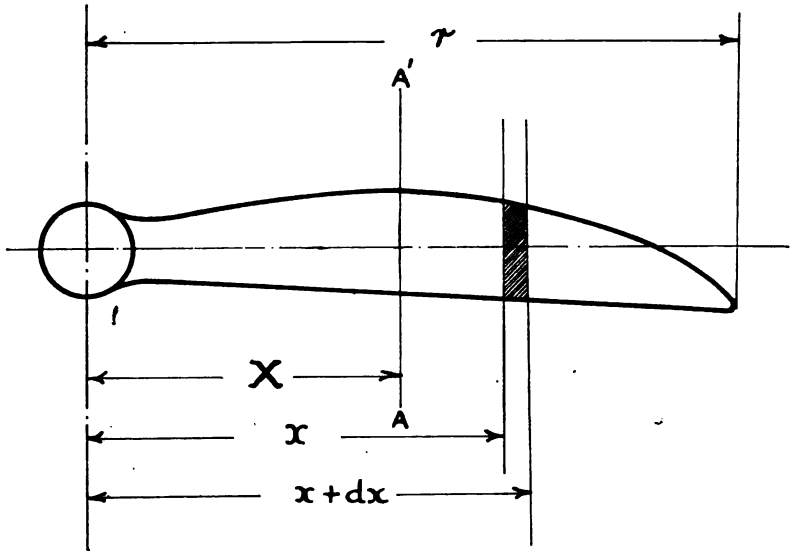

FIG. 33.

And let (a) = area of element considered in sq. ins.

And therefore $\frac{a}{144}$ = area of section of element considered in sq. ft.

And therefore volume of element = $\frac{a \cdot dx}{144}$ cu. ft.

And therefore weight of element = $\frac{w \cdot a \cdot dx}{144}$ lbs.

And circumferential velocity of element is equal to

$$(2 \cdot \pi \cdot x \cdot n) \text{ ft./sec.}$$

So that we may write

$$dF = \frac{w.a.dx.4.\pi^2.n^2.x}{144.g},$$

giving the centrifugal pull on AA' due to the element considered.

Hence the total pull on AA' is given by

$$F = \frac{\pi^2.n^2.w}{36.g} \int_{x=X}^{x=r} a.x.dx \text{ lbs.}$$

Whence the stress due to the centrifugal pull at AA' is given by

$$\frac{F}{a_1} = \frac{\pi^2.n^2.w}{36.g.a_1} \int_{x=X}^{x=r} a.x.dx \text{ lbs./sq. in.,}$$

where (a_1) is equal to the area of the section at AA' in sq. ins.

Now (a) denotes the area in sq. ins. of the section at radius (x) from the boss centre, and consequently the value of (a) may vary with (x). It is, however, a simple matter to evaluate graphically the expression for $\frac{F}{a_1}$, if necessary.

We have then

Stress due to centrifugal action at any section distance (X)

from the boss centre = $\frac{F}{a_1}$ lbs./sq. in.,

where

$$\frac{F}{a_1} = \frac{\pi^2.n^2.w}{36.g.a_1} \int_{x=X}^{x=r} a.x.dx.$$

We may at once estimate the tensile stress, due to centrifugal action, near the boss of the air-screw, if we assume that

- (1) The blade width is uniform, and
- (2) The blade section is constant, except near the boss.

Then we have at once that

$$\frac{F}{a_1} = \frac{\pi^2 n^2 w a}{36 g a_1} \int_{x=X}^{x=r} x dx$$

since (a) is constant

$$= \frac{(\pi^2 n^2 w a)}{72 g a_1} \left(\frac{r^2}{2} - \frac{X^2}{2} \right) \text{ lbs./sq. in.}$$

And this formula holds good for any value of (X) providing the initial assumptions (1) and (2) are satisfied.

Since near the boss (X) may be taken equal to zero, the formula becomes

$$\frac{F}{a_1} = \frac{\pi^2 n^2 w a r^2}{72 g a_1} \text{ lbs./sq. in.,}$$

and this gives the value of the tensile stress at or near the boss due to the centrifugal pull of the whole blade.

An example will make the application of this result clearer.

Let (n) = 20 revs./sec., (r) = 4 ft., (w) = 35 lbs./cu. ft.,

(a) = 7 sq. ins., and (a_1) = 16 sq. ins.

Then, taking the value of (π^2) as being equal to 10, we get

$$\frac{F}{a_1} = \frac{10.400.35.7.16}{72.32.16} = 425 \text{ lbs./sq. in.}$$

Hence the amount of the tensile stress at or near the boss, due to the centrifugal pull of the whole blade, is equal to 425 lbs./sq. in. This result is quite in the usual order of practical work.

Stresses due to bending.

The stresses in the blades due to bending are due to the resultant air pressure exerted upon each element of the blade.

Consider any section as in Fig. (34).

And let (Y_c) = the distance in inches of the extreme ordinate of the section from the neutral axis passing through the centre of area of the section.

And let (Y_t) = the distance in inches of the chord line, assuming the sections to be flat underneath, from the neutral axis.

Then the extreme values of the tensile and compressive stresses occur at the layers of the material most remote from the neutral axis.

So that we have

Maximum value of compression stress at any section in
lbs./sq. in. = compressive stress at outside fibres

$$= \frac{M.Y_c}{I}$$

And similarly,

Maximum value of tension stress at same section in
lbs./sq. in. = tension stress at outside fibres

$$= \frac{M.Y_t}{I}$$

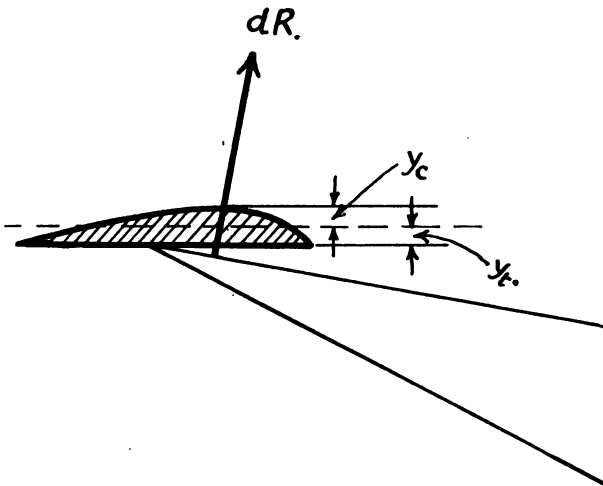

FIG. 34.

where (M) = bending moment at section considered, and
(I) = moment of inertia of the area of the section about
the neutral axis,

and (Y_c) and (Y_t) have already been defined.

If the values of $\frac{M.Y_c}{I}$ and $\frac{M.Y_t}{I}$ be then worked out for
various values of the radius (X), we can determine the values

G.

of the max. compressive and max. tensile stresses due to bending and centrifugal force.

For we have

Max. compressive stress at any section, due to bending and centrifugal force = $\frac{M.Y_c}{I}$ - centrifugal stress at section.

And similarly,

Max. tensile stress at the same section, due to bending and centrifugal force = $\frac{M.Y_t}{I}$ + centrifugal stress at section.

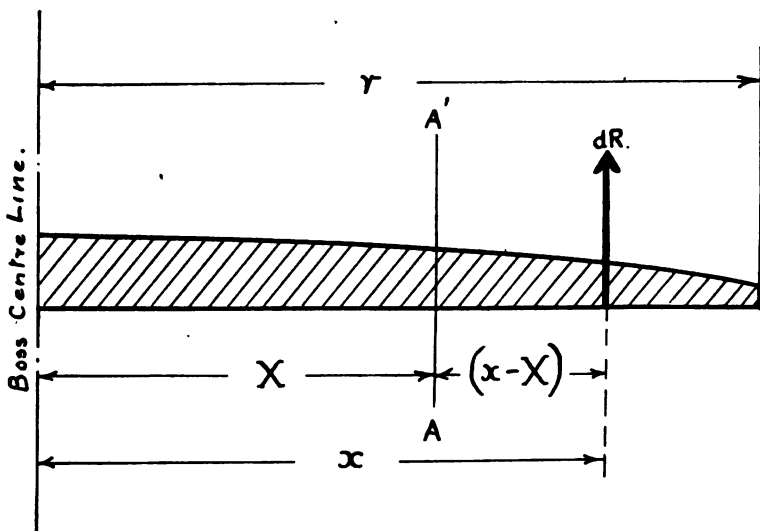

FIG. 35.

And if this be done for several sections of the radius (X) we shall obtain the "maximum maximorum" stress at some radius, which stress must not exceed the safe working stress of the material used in the construction of the air-screw.

We have then to determine the Bending Moment (M_x) at any distance (X) from the boss centre, that is, at any section considered along the blade.

Let Fig. (35) represent a side elevation of the air-screw blade.

Consider a section at AA' at a distance (X) from the boss

centre. Then the Bending Moment at AA' is equal to the sum of all the B.M.'s at the sections from AA' to the blade tip.

Let (x) be any radius from the boss centre, lying between AA' and the blade tip, and let (dR) represent the resultant air-pressure at this section. The value of (dR) has already been determined in terms of the radius (x) .

Then B.M. at AA' due to the force $(dR) = (dR) \cdot (x - X)$, and therefore

the total B.M. at AA' at a radius (X) from the boss centre

$$= \int_{x=X}^{x=r} dR \cdot (x - X).$$

Now

$$(dR) = \rho \cdot n^2 \cdot b \cdot c_y \cdot (P^2 + 4 \cdot \pi^2 \cdot x^2) \cdot \sec \gamma \cdot dx,$$

so that

$$\int_{x=X}^{x=r} dR \cdot (x - X) = \rho \cdot n^2 \cdot \int_{x=X}^{x=r} (x - X) \cdot b \cdot c_y \cdot (P^2 + 4 \cdot \pi^2 \cdot x^2) \cdot \sec \gamma \cdot dx$$

= B.M. at AA' at a distance of (X) from the boss centre.

We are now able to calculate the value of the B.M. on any section at any distance from the boss centre.

Since we may without appreciable error take the value of $(\sec \gamma)$ as equal to unity, the above becomes

$$M_X = \rho \cdot n^2 \cdot \int_{x=X}^{x=r} (x - X) \cdot b \cdot c_y \cdot (P^2 + 4 \cdot \pi^2 \cdot x^2) \cdot dx,$$

and, since (R) is usually measured in lbs., (x) and (X) will be measured in feet, when $(\rho) = .00238$, and therefore the value of (M_X) will be obtained in lbs./ft.

But, since (Y_c) , (Y_t) and (I) are usually measured in inches, (M_X) must also be measured in inches in order to give the stresses in lbs./sq. in.

Hence we must multiply the value of (M_X) , obtained from the formula already given, by (12).

So that we then have

B.M. at (X) in lbs./in. = (12) $\cdot (M_X)$, which is equal to

$$12 \cdot \rho \cdot n^2 \int_{x=X}^{x=r} (x - X) \cdot b \cdot c_y \cdot (P^2 + 4 \cdot \pi^2 \cdot x^2) \cdot dx,$$

and we may evaluate this at once if we assume that the conditions (1) and (2) already given are satisfied, so that (b) and (c_y) are constants over the blade.

To estimate the Bending Moment at or near the boss, we put (X) equal to zero, and the formula then becomes

$$\text{B.M. at } (X) \text{ in lbs./in.} = 6 \cdot \rho \cdot n^2 \cdot b \cdot c_y \cdot r^2 \cdot (P^2 + 2 \cdot \pi^2 \cdot r^2),$$

and if we take as an example that

$\rho = \cdot 00238$, $n = 20$, $r = 4$, $b = \cdot 75$, $c_y = \cdot 2$, $P = 5$, $\pi^2 = 10$, we have

B.M. in lbs./in. at or near the boss is equal to

$$\begin{aligned} (6) (\cdot 00238) (400) (\cdot 75) (\cdot 2) (16) (25 + 20 \times 16) \\ = 4728 \text{ lbs./in.} \end{aligned}$$

Now we have the maximum value of Compression stresses at (X) ft. from the boss centre, due to Bending Moment and centrifugal force in lbs./sq. in. = $12 \cdot \frac{M_X \cdot Y_c}{I}$ - centrifugal stress

$$\begin{aligned} &= \frac{12 \cdot M_X \cdot Y_c}{I} - \frac{F}{a_1} \\ &= \frac{12 \cdot Y_c}{I} \cdot \rho \cdot n^2 \cdot \int_X^r (x - X) \cdot b \cdot c_y \cdot (P^2 + 4 \cdot \pi^2 \cdot x^2) \cdot dx \\ &\quad - \frac{\pi^2 \cdot n^2 \cdot w}{36 \cdot g \cdot a_1} \int_X^r a \cdot x \cdot dx. \end{aligned}$$

And similarly the maximum value of the Tension stresses at (X) feet from the boss centre due to Bending Moment and centrifugal force in lbs./sq. in. = $12 \cdot \frac{M_X \cdot Y_t}{I}$ + centrifugal stress

$$\begin{aligned} &= \frac{12 \cdot M_X \cdot Y_t}{I} + \frac{F}{a_1} \\ &= \frac{12 \cdot Y_t}{I} \cdot \rho \cdot n^2 \cdot \int_X^r (x - X) \cdot b \cdot c_y \cdot (P^2 + 4 \cdot \pi^2 \cdot x^2) \cdot dx \\ &\quad + \frac{\pi^2 \cdot n^2 \cdot w}{36 \cdot g \cdot a_1} \int_X^r a \cdot x \cdot dx. \end{aligned}$$

And we may now obtain the values of both the maximum Tension and maximum Compression stresses at any distance (X) feet from the boss centre.

If then the values of these stresses be worked out for several values of (X) , we shall obtain a "maximum maximorum" value for the Tension and Compression stresses at some particular value of (X) .

The greatest of these two values so obtained must not exceed the safe working stress of the material of which the blades of air-screws are made. An approximate value for the safe working load of walnut is 2000 lbs./sq. in.

CHAPTER VII.

STATIC THRUST.

THE supposed "effectiveness" of an air-screw is sometimes thought to depend upon the "pull" it exerts when revolving on the ground, that is when the aeroplane to which it is attached is being held back prior to a flight.

Now although what may be termed the "Static" thrust of an air-screw cannot be considered as necessarily being a criterion of efficiency, yet it is interesting to see how far it is possible to predict quantitative values for this thrust when considered in the light of the aerofoil theory.

It is quite evident that the analogy still holds in this case, for we may consider each section along the blade as moving with a definite velocity and hence exerting a definite thrust, although the air-screw is acting like a fan, since it has no velocity in a direction normal to the disc of revolution of the blades.*

The helix angles (A) are thus equal to zero, and the "angles of attack" (α) must therefore be considered as being equal to the actual measured chord angles at the various radii.

Thus (P) = 0, and (α) = (ϕ).

The general expression for the thrust on an air-screw blade for any value of $\frac{V}{n}$ is given by

$$T = c.\rho.n^2 \int_{r_0}^{r} f(x) \cdot \phi(x) \cdot (2.\pi.x - P.\psi(x)) \cdot \sqrt{P^2 + 4.\pi^2.x^2} \cdot dx.$$

* Owing to some of the speeding up of air occurring before the air-screw is reached, the theory cannot be applied directly without very appreciable error. This error is not so great in the case of stationary air-screws working in an enclosing channel.

And, since in this case $(P) = 0$, this becomes

$$T = 4.\pi^2.c.\rho.n^2. \int_{r_0}^r f(x). \phi(x). x^2. dx.$$

And this can be evaluated for any form of air-screw blade considered.

Let us suppose however that the blade widths are uniform from boss to tip, and that the section is also uniform.

We may regard $(r_0) = 0$, so that we get

$$T = 4.\pi^2.\rho.b.n^2.c_y. \int_0^r x^2. dx$$

and \therefore
$$T = \frac{\pi^2.\rho.b.n^2.c_y.d^3}{6},$$

which gives an approximate value for the "Static" thrust on each blade.

The value of (c_y) will depend upon the form of the blade sections at the outside radii, and the "average" values of (ϕ) , the chord angles of the blade to the air-screw's disc of revolution.

Approximate values for (c_y) can be obtained from reference to tests carried out on sections similar in form to those employed at the outside radii of the blade and at angles of the same amount as the "average" chord angles.

(c_y) often has a value of about (.4).

It is useful, however, to obtain this "Static" thrust expression in terms of the horse-power of the motor.

Since

$$N.T = \frac{550.H.\eta}{V} = \frac{550.H.\eta}{P.n}$$

in lb./ft./sec. units, we obtain

$$N.T = \frac{2200. H}{3.\pi.n.d. \tan \gamma}$$

The value of $(\tan \gamma)$ depends upon the values of the outside chord angles.

If we take $(\tan \gamma) = \frac{1}{3}$, we get

$$N.T = \frac{700.H}{n.d'}$$

This formula, while being very simple, is of course only a very approximate one.

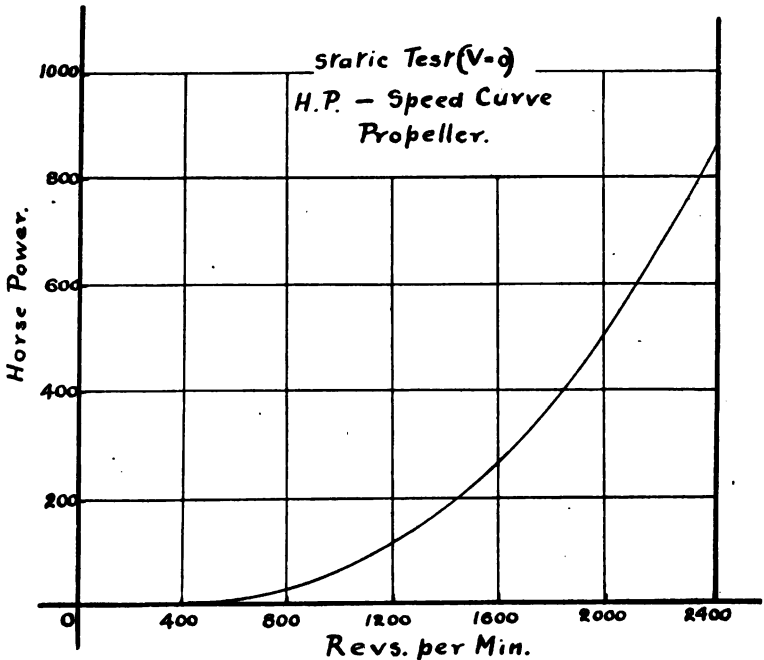

FIG. 36.

If as an example

$H = 40, n = 20, d = 8$, we get

$$N.T = \frac{700 \times 40}{20 \times 8} = 175 \text{ lbs.}, \text{ a very low figure.}$$

In any case, however, it would appear that we can put the expression for the "Static" thrust into the form

$$N.T = \frac{\lambda.H}{n.d'}$$

where (λ) has a value in the neighbourhood of (1000).

Suppose

$H = 40, n = 8, d = 8, \lambda = 1000$; then

$$N.T = \frac{1000 \times 40}{8 \times 8} = 625 \text{ lbs.}$$

We notice that the "Static" thrust increases inversely as the rate of revolution of the air-screw, so that we should expect a slow-running, *i.e.* geared-down, air-screw to have a higher

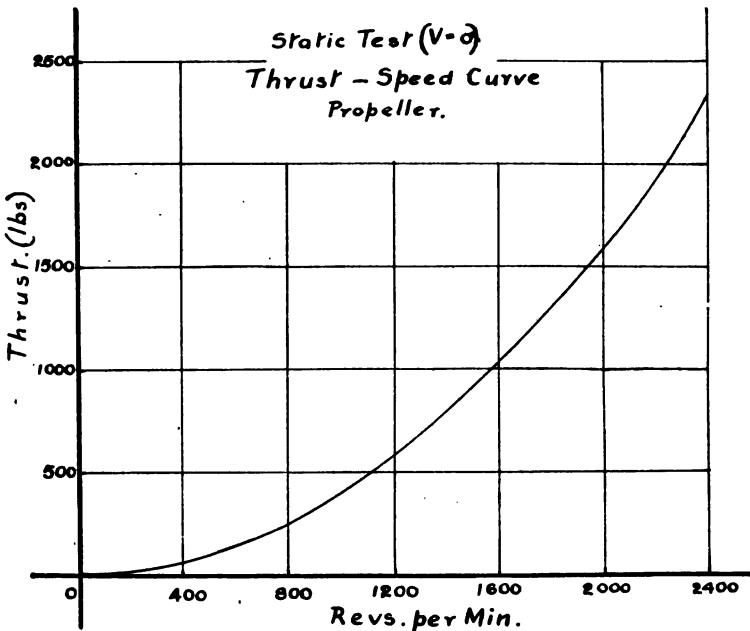

FIG. 37.

"Static" thrust than one which was coupled direct to the motor, for the same horse-power.

The "Static" thrust of an air-screw on an aeroplane is usually measured by attaching a spring balance to the rear portion of the machine and attaching a rope from the spring balance to some fixed support.

We see also from the general formula for the static thrust of an air-screw that the static thrust varies as the square of the

rotational speed, and that the necessary B.H.P. required to turn the air-screw varies as the cube of the rotational speed.

This is borne out approximately by experimental tests on air-screws, as Figs. (36), (37) will show. These Figures are taken from the results of tests carried out at the National Physical Laboratory by Mr. F. H. Bramwell and Mr. A. Fage.*

We notice from these experimental curves that for a static thrust of approximately 1050 lbs. on an 8 ft. diameter air-screw having a rotational speed of 1600 revs. per min., the B.H.P. necessary is approximately 270. Hence if we apply the formula deduced for the static thrust we may determine an approximate value for the constant (λ).

We have

$$\text{Total static thrust of air-screw} = N.T = \frac{\lambda.H}{n.d},$$

whence

$$1050 = \frac{\lambda.270.60}{1600.8},$$

and therefore

$$(\lambda) = 830.$$

This value is rather smaller than the value proposed, from reference to actual static tests carried out on aeroplane air-screws, for this constant, namely 1000.

* See "The Aeroplane," by A. Fage, A.R.C.Sc. (Charles Griffin & Co.).

CHAPTER VIII.

EFFICIENCY OF AN AIR-SCREW AT DIFFERENT SPEEDS OF
TRANSLATION.

PRESENT day aircraft, whether aeroplanes or dirigibles, have as a rule two distinct limiting speeds of flight. In the dirigible the minimum speed will of course be zero, but in the aeroplane this is not so, and the minimum possible speed of flight for any given type may be calculated approximately when the characteristics of the machine are known.

Now between these two limiting speeds, that is between the minimum and maximum climbing speeds, there will be an infinite range of speeds at which the aeroplane may fly. That is to say that, if an aeroplane has a maximum velocity of say 100 feet per second and a minimum velocity of say 50 feet per second, then between these two outside speeds the aeroplane has an infinite number of different velocities at which it may fly.

Now it will usually be found that in the case of an aeroplane the speed at which it is able to climb fastest, that is the speed at which the reserve thrust horse-power of the motor is greatest, will lie between its maximum and minimum speeds and will usually be nearer the latter.

If we examine the thrust horse-power curve of an aeroplane it will usually be found that the ordinates on the curve have at some value of the abscissæ (in this case velocity) a minimum value, and the velocity corresponding to this minimum point will be the velocity at which the thrust horse-power required for horizontal flight is a minimum, and hence the reserve thrust horse-power is a maximum, that is the velocity of ascent will be greatest at this value of the velocity.

Now this is only true when the efficiency of the air-screw is supposed to remain constant throughout the interval between the maximum and minimum speeds of flight. In practice, however, this is never so, since the air-screw is usually designed for the maximum flight velocity, and hence for any other value of the velocity the efficiency of the air-screw falls off.

Hence the curve of available thrust horse-power is now no longer a straight line, and therefore the maximum difference between the ordinates of this curve and the curve of thrust horse-power required for horizontal flight will no longer necessarily occur at the velocity corresponding to the minimum value of the thrust horse-power required for horizontal flight, but will usually be found to occur at a value of the flight velocity slightly greater than this value.

Now in order to be able to determine this point on the curve and hence the maximum rate of climb possible and also the speed of flight corresponding to this maximum climb, it is necessary to know how the efficiency of the air-screw varies for different values of (V), the velocity of flight. Experimental results of tests on air-screws have been obtained for various types and curves of efficiency plotted against values of (V).

It is interesting, however, to attempt to predict the amount of this variation in efficiency from the results already obtained on the assumption of the aerofoil analogy.

We have already obtained an expression for the efficiency of any type of air-screw at any value of the effective pitch $\frac{V}{n}$, that is at any value of the velocity of advance (V).

Hence we may, providing we possess the necessary information with regard to the values of the lift and $\frac{\text{lift}}{\text{drag}}$ of the sections at various angles of incidence, determine the value of (η), the efficiency of the air-screw, under varying sets of conditions and for various values of the translational velocity.

Now it has already been shown that the results obtained from the "Rational" blade form in many cases approximate very closely to standard types of air-screw blades, and we shall therefore use this form of blade in the quantitative determina-

tion of the values of (η) for various values of the velocity of advance (V) .

This modification is introduced for convenience and simplicity of working out the numerical examples, which become very tedious when treated from the most general expression for efficiency.

We have then the efficiency of an air-screw of this type is given by

$$\eta = \frac{P \int_{r_0}^r x \cdot \phi(x) \cdot (2 \cdot \pi \cdot x - P \cdot \psi(x)) \cdot dx}{2 \cdot \pi \cdot \int_{r_0}^r x^2 \cdot \phi(x) \cdot (P + 2 \cdot \pi \cdot x \cdot \psi(x)) \cdot dx}$$

for any value of $(P) = \frac{V}{n}$, and we proceed to discuss the variation in the value of (η) for variations in the value of (V) .

Now it is not proposed to attempt to evaluate algebraically the expression for (η) for any value of $\frac{V}{n}$, since to do so would necessitate the determination of at least approximate equations for the two functions $\phi(x)$ and $\psi(x)$ for each value of $\frac{V}{n}$ considered.

We shall therefore employ a graphical method in this investigation.

It will be necessary to determine the value of (η) , the efficiency of the air-screw, for several values of the advance per revolution $\frac{V}{n}$, and when these values have been obtained a smooth curve drawn through the points will give at any rate a near approximation to the value of the air-screw's efficiency at any value of the velocity (V) considered.

We have then to plot the two graphs of

$$x \cdot \phi(x) \cdot (2 \cdot \pi \cdot x - P \cdot \psi(x))$$

and

$$x^2 \cdot \phi(x) \cdot (P + 2 \cdot \pi \cdot x \cdot \psi(x))$$

for each value of $\frac{V}{n}$ taken, then determine the two areas

enclosed by each respectively, the extreme ordinates at radii of (r_0) and (r), and the (x) axis, divide the area thus enclosed by the first curve by the area enclosed by the second curve, and multiply the result by $\frac{V}{2\pi n}$, where (V) has the particular value of the velocity of advance chosen. The value of (P) in each case will then of course be $\frac{V}{n}$, (V) having the particular value already defined.

Since we know the form of the blade sections at various radii we may, by reference to tests carried out in a wind-channel on sections of similar form, determine the probable values of (c_y) and ($\tan \gamma$), that is of $\phi(x)$ and $\psi(x)$, of the sections at these radii when we know the respective values of the angles of attack of the sections considered.

We may determine the values of these angles of attack for each value of (V), and hence of $\frac{V}{n}$, chosen as follows.

We must first determine the values of the chord angles (ϕ) at the radii considered, and we can do this either by direct measurement of these angles on the air-screw, or, if we know for what value of $\frac{V}{n}$ the air-screw is designed, it is only necessary to determine the values of (ϕ) for any radius chosen from the relation

$$\phi_x = a_x + \tan^{-1} \left(\frac{P}{2\pi x} \right),$$

where (P) has the value of the designed effective pitch, that is the value of the velocity of the aircraft (usually the maximum velocity) for which the air-screw is designed, divided by the value of (n) at this velocity.

(a_x) is the value of the "angle of attack" of a section at radius (x), for the velocity of the aircraft for which the air-screw is designed.

(a_x) may be termed the "initial angle of attack" of any section at radius (x).

Having then found the value of (ϕ_x), the chord angle for

any radius (x), we may proceed to determine the new value of (α_x) for the various values of (V) considered.

Since the effective pitch has now a different value from its "initial" designed value, we may denote it by (P'), and the new "angles of attack" at each radius (x) by (α_x'). We then have at once that

$$\alpha_x' = \phi_x - \tan^{-1} \left(\frac{P'}{2\pi x} \right),$$

and we are now in a position to make the following table for each value of (V) taken.

Section No.	7	6	5	4
Radius (x) feet .	1 foot	2 feet	3 feet	4 feet
Chord angle at } radius (x) . . }	42° 30'	25° 42'	18° 51'	15° 15'
Angle of attack } at radius (x) }	10°	8°	7°	6° 13'
Abs. lift coeff. at } radius (x) . . }	·338	·525	·475	·425
Drag } lift ratio at } radius (x) . . }	$\frac{1}{3\cdot4}$	$\frac{1}{9\cdot8}$	$\frac{1}{10\cdot5}$	$\frac{1}{12}$

The above table has been taken as an example. It is for an air-screw designed for a velocity of advance (V) of 100 feet per sec., and a speed of revolution (n) of 20 revs. per second. The value of the effective pitch is thus 5 feet, and the table given is for the case considered when the velocity of advance is 80 feet per second, so that the new value of the effective pitch is 4 feet. The sections are those given in the "Technical Report of the Advisory Committee for Aeronautics, 1911-12," page 76, and already referred to in a previous chapter.

The values of $\phi(x)$ and $\psi(x)$ are taken from the curves plotted as a result of tests in a wind-channel on these sections at the National Physical Laboratory.

Similar tables to the one given may now be obtained for several other values of $\frac{V}{n}$ from zero up to and beyond the

designed velocity of flight. From each of these tables we may plot two curves, the curves respectively of

$$x.\phi(x). (2.\pi.x - P.\psi(x))$$

and

$$x^2.\phi(x). (P + 2.\pi.x.\psi(x)),$$

and the two areas enclosed by these two curves may then be found in each case. We may thus calculate the efficiency of the air-screw for each value of $\frac{V}{n}$ chosen, and the values so obtained can then be plotted against their respective values of (V) , giving a curve of efficiency for any value of the velocity of advance of the air-screw considered.

It will be found that when $(V) = 0$, then $(\eta) = 0$, and that when (V) has values appreciably greater than the designed value of (V) the value of (η) rapidly falls off.

An example will make the application of this method clearer.

Let

(V) the designed or initial value of the flight velocity of the aircraft = 100 ft. per second.

(n) the speed of revolution of the air-screw at this value of $(V) = 20$ revs. per second.

Then (P) the initial value of the effective pitch = 5 feet.

(d) the diameter of the air-screw = 8 feet.

(a_x) the initial angles of attack of the sections along the blade = $4^\circ =$ constant over blade.

Let the sections along the blade be those already referred to and let them be spaced as follows:—

At a radius of 1 foot, section no. 7.

„ „ 2 feet, „ „ 6.

„ „ 3 „ „ 5.

„ „ 4 „ „ 4.

We may then form the following table:—

$$\frac{V}{n} = 5 \text{ feet.}$$

Section No.	7	6	5	4
ϕ_x	42° 30'	25° 42'	18° 51'	15° 15'
a_x	4°	4°	4°	4°
$\phi(x)$	·416	·384	·374	·344
$\psi(x)$	$\frac{1}{10\cdot2}$	$\frac{1}{11\cdot4}$	$\frac{1}{11\cdot8}$	$\frac{1}{12\cdot8}$
x	1 foot	2 feet	3 feet	4 feet

From this table plot the two graphs of

$$x \cdot \phi(x) \cdot (2 \cdot \pi \cdot x - P \cdot \psi(x))$$

and

$$x^2 \cdot \phi(x) \cdot (P + 2 \cdot \pi \cdot x \cdot \psi(x))$$

taking values of $\phi(x)$ and $\psi(x)$ for each value of (x) taken from the above table. (P) has of course the value of (5).

These two curves are shown plotted in Fig. 38.

The efficiency of the air-screw under these conditions is seen to be 75%.

Now take successive values of $\frac{V}{n}$, of say 1 ft., 2 ft., 3 ft., 4 ft., 6 ft., and 7 ft., and in each case form the corresponding table. These tables are given below in order.

$$\frac{V}{n} = 1 \text{ foot.}$$

Section No.	7	6	5	4
ϕ_x	42° 30'	25° 42'	18° 51'	15° 15'
a_x	33° 28'	21° 9'	15° 49'	13°
$\phi(x)$..	·44	·41	·53
$\psi(x)$..	$\frac{1}{2\cdot2}$	$\frac{1}{3\cdot1}$	$\frac{1}{7}$
x	1 foot	2 feet	3 feet	4 feet

H

$$\left(\frac{V}{n}\right) = 5 \text{ feet.}$$

{ Area enclosed by Top Curve = 19.38 sq. ins. }
 { " " " " Lower " = 20.63 " " }

$$\therefore \eta = \frac{5}{2\pi} \cdot \frac{19.38}{20.63} = .75$$

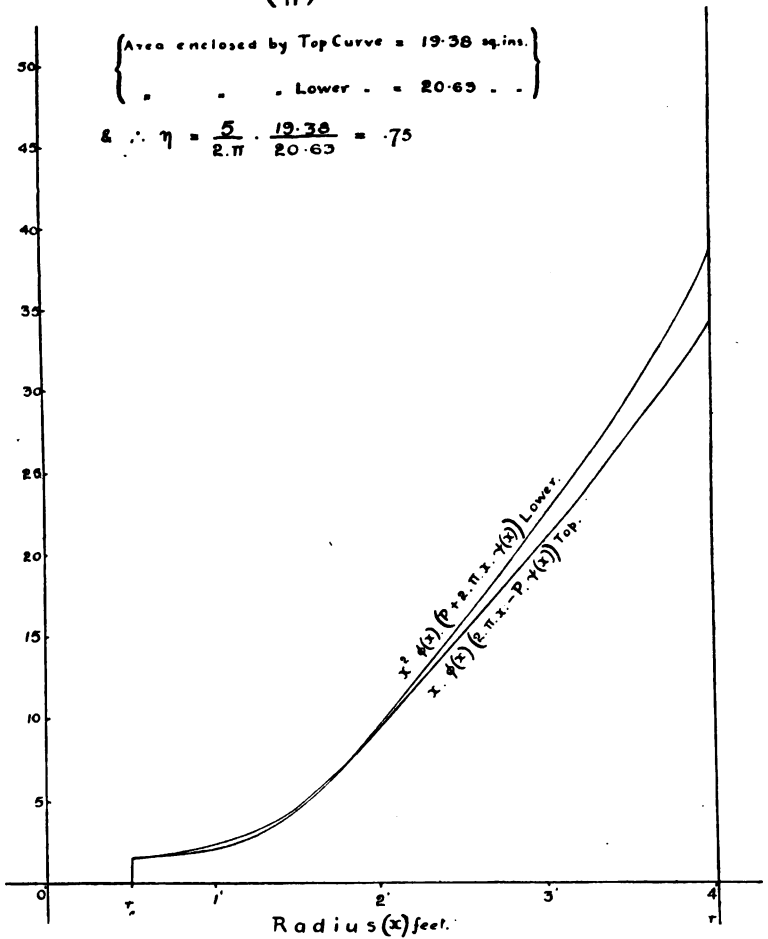

FIG. 38.

$$\frac{V}{n} = 2 \text{ feet.}$$

Section No.	7	6	5	4
ϕ_x	42° 30'	25° 42'	18° 51'	15° 15'
a_x	25°	16° 40'	12° 48'	10° 42'
$\phi(x)$	·48	·39	·425	·575
$\psi(x)$	$\frac{1}{2}$	$\frac{1}{2\cdot5}$	$\frac{1}{4\cdot3}$	$\frac{1}{10}$
x	1 foot	2 feet	3 feet	4 feet

$$\frac{V}{n} = 3 \text{ feet.}$$

Section No.	7	6	5	4
ϕ_x	42° 30'	25° 42'	18° 51'	15° 15'
a_x	17°	12° 18'	9° 49'	8° 27'
$\phi(x)$	·38	·38	·56	·5
$\psi(x)$	$\frac{1}{2\cdot3}$	$\frac{1}{3\cdot7}$	$\frac{1}{9}$	$\frac{1}{11}$
x	1 foot	2 feet	3 feet	4 feet

$$\frac{V}{n} = 6 \text{ feet.}$$

Section No.	7	6	5	4
ϕ_x	42° 30'	25° 42'	18° 51'	15° 15'
a_x	-1° 11'	0° 11'	1° 18'	1° 48'
$\phi(x)$	·25	·26	·275	·25
$\psi(x)$	$\frac{1}{7\cdot5}$	$\frac{1}{9}$	$\frac{1}{10\cdot5}$	$\frac{1}{11}$
x	1 foot	2 feet	3 feet	4 feet

$$\frac{V}{n} = 7 \text{ feet.}$$

Section No.	7	6	5	4
ϕ_x	42° 30'	25° 42'	18° 51'	15° 15'
a_x	- 5° 30'	- 8° 20'	- 1° 27'	- 0° 21'
$\phi(x)$	·06	·12	·17	·15
$\psi(x)$	$\frac{1}{1.5}$	$\frac{1}{3.5}$	$\frac{1}{6}$	$\frac{1}{7}$
x	1 foot	2 feet	3 feet	4 feet

From these tables plot the curves given in Figs. 39, 40, 41, 42, 43, and 44.

The respective efficiencies are seen to be as follows.

The value of (n) has been supposed to remain constant throughout. This assumption does not affect in any way the generality of the method.

At a speed of translation of 20 ft./sec.,	$\frac{V}{n} = 1 \text{ ft.},$	$(\eta) = 15.5\%$
„ „ „ 40 „	„ = 2 „	„ = 32.6%
„ „ „ 60 „	„ = 3 „	„ = 54.5%
„ „ „ 80 „	„ = 4 „	„ = 67%
„ „ „ 120 „	„ = 6 „	„ = 76.7%
„ „ „ 140 „	„ = 7 „	„ = 62.7%

A curve of efficiency against values of (V) may now be plotted, Fig. (45).

It will be noticed that when $\frac{V}{n} = 6 \text{ ft.}$, i.e. at a velocity of translation of 120 ft. per second, the efficiency of the air-screw is higher than the efficiency at the speed for which it is designed. This is due to the fact that the value of (Z), i.e. $\frac{P}{d}$, is greater than the initial value, and, although the $\frac{\text{lift}}{\text{drag}}$ of the individual sections is less than in the initial case, yet

$$\left(\frac{v}{n}\right) = 1 \text{ foot.}$$

$$\left\{ \begin{array}{l} \text{Area enclosed by Top Curve} = 22.82 \text{ sq. ins.} \\ \text{Area enclosed by Lower Curve} = 23.5 \text{ sq. ins.} \end{array} \right.$$

$$\therefore \eta = \frac{1}{2. \pi} \cdot \frac{22.82}{23.5} = .155$$

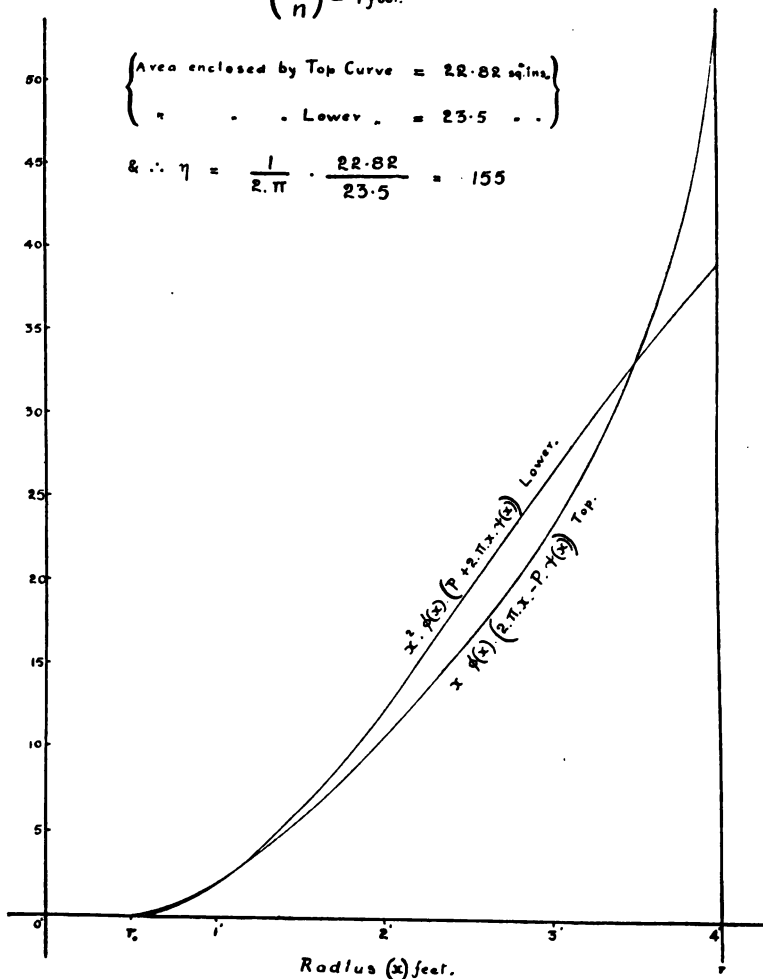

FIG. 89.

$$\left(\frac{V}{n}\right) = 3 \text{ feet.}$$

{ Area enclosed by Top Curve. = 26.14 sq. ins.
 Lower . . . = 22.88 . . . }

$$\therefore \eta = \frac{3}{2 \cdot \pi} \cdot \frac{26.14}{22.88} = .545$$

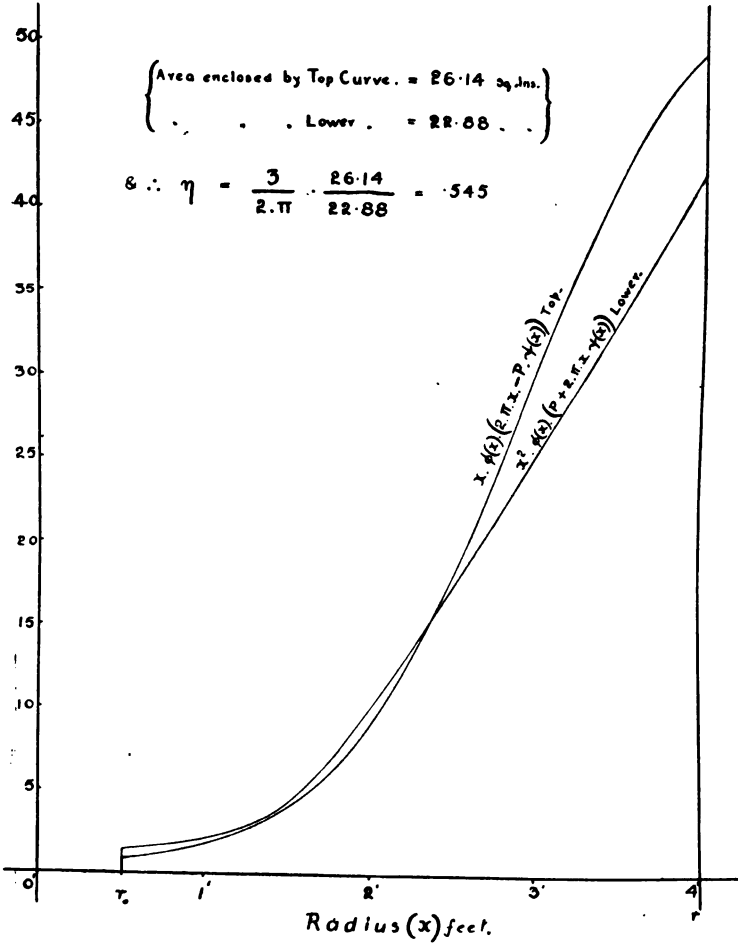

FIG. 41.

$$\left(\frac{V}{\pi}\right) = 4 \text{ feet.}$$

$$\left\{ \begin{array}{l} \text{Area enclosed by Top Curve} = 24.34 \text{ sq. ins.} \\ \text{Area enclosed by Lower Curve} = 23.14 \text{ sq. ins.} \end{array} \right.$$

$$\begin{aligned} \therefore \eta &= \frac{V}{2\pi R} \cdot \frac{\text{Area enclosed by Top Curve}}{\text{Area enclosed by Lower Curve}} \\ &= \frac{2}{\pi} \cdot \frac{24.34}{23.14} \\ &= .67 \end{aligned}$$

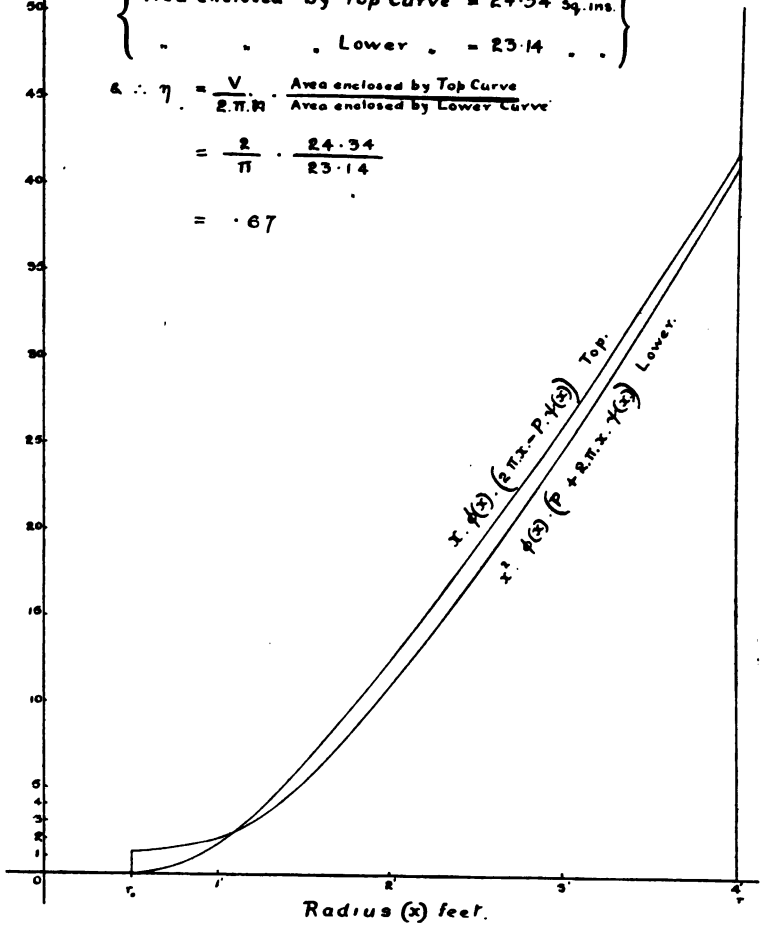

FIG. 42.

$$\left(\frac{V}{\pi}\right) = 6 \text{ feet.}$$

{ Area enclosed by Top Curve = 13.55 sq. ins. }
 { Lower . . . = 16.84 . . . }

$$\therefore \eta = \frac{6}{2 \cdot \pi} \cdot \frac{13.55}{16.84} = .767$$

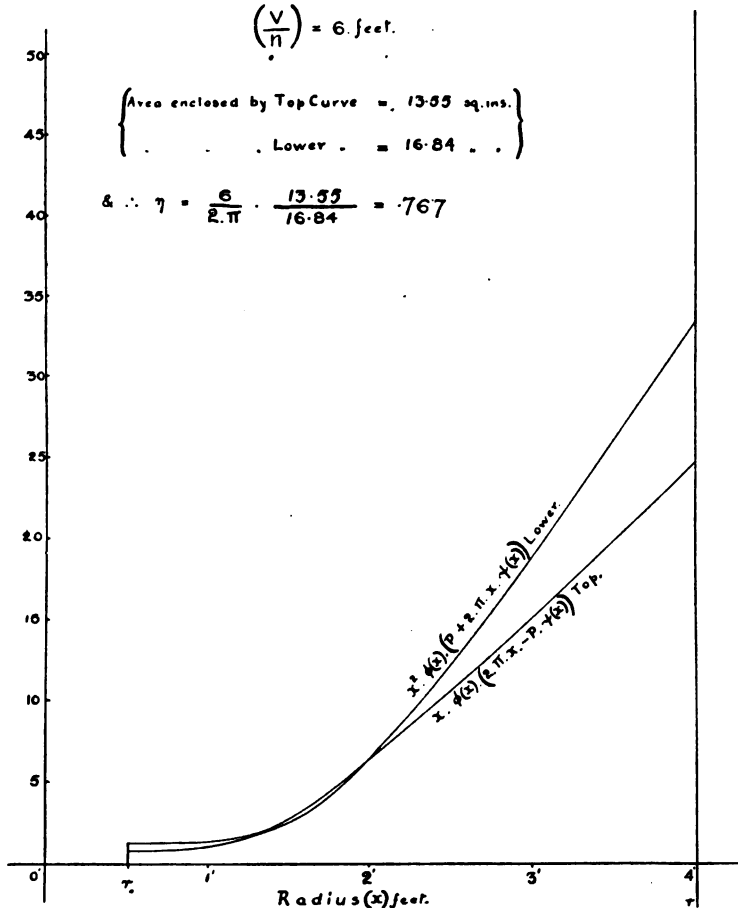

FIG. 48.

$$\left(\frac{V}{n}\right) = 7 \text{ feet.}$$

$$\left\{ \begin{array}{l} \text{Area enclosed by Top Curve} = 7.54 \text{ sq. ins.} \\ \text{Lower} = 13.4 \end{array} \right.$$

$$\therefore \eta = \frac{7}{2.11} \cdot \frac{7.54}{13.4} = .627$$

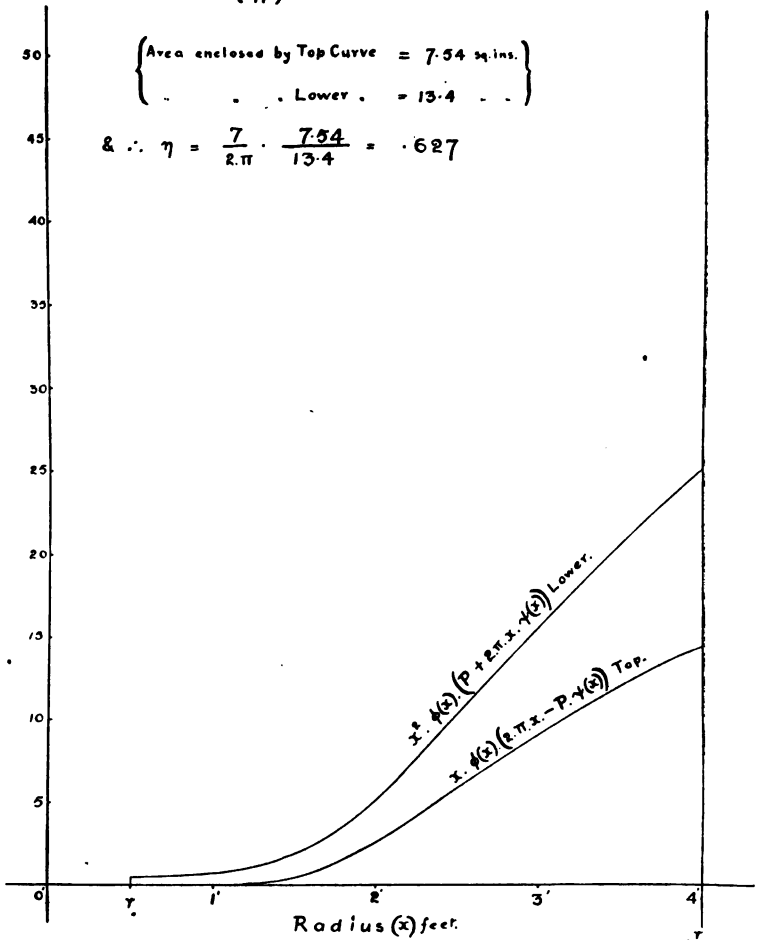

FIG. 44.

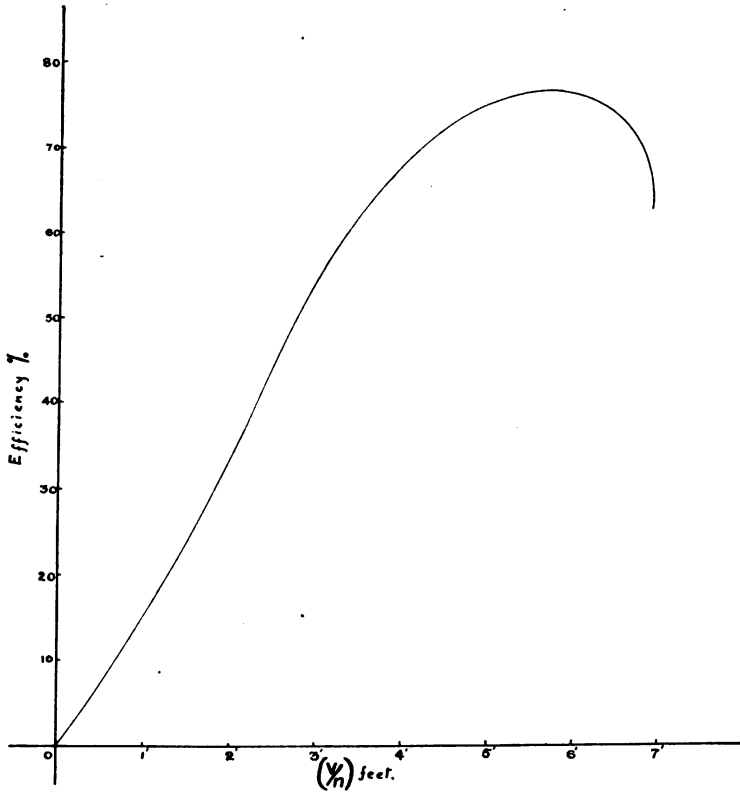

FIG. 45.

the higher value of (Z) makes a preponderance in the efficiency of the whole blade. At a value of $\frac{V}{n} = 7$ ft., however, we notice that the efficiency is very much smaller in spite of the still higher value of (Z).

Of course if the air-screw was designed initially for a value of $\frac{V}{n} = 6$ ft., the efficiency would be greater than that now given at this value of $\frac{V}{n}$, providing of course that the spacing and forms of the sections, etc., remained the same as in the initial case here considered.

This curve of efficiency against values of translational velocity (V) appears to conform to curves obtained by experiment on similar types of air-screws.

CHAPTER IX.

DIRECT LIFTING SYSTEMS.

WHEN a force (P) moves its point of application through a distance (s), in the direction of the force, it is said to do (P.s) units of work.

If a weight of (W) lbs. be lifted through a distance of (x) feet the work done against gravity is (W.x) foot-lbs., supposing the distance (x) to be negligible in comparison with the earth's radius.

Now suppose that a body of weight (W) lbs. is being lifted against gravity at a uniform speed of (V) feet/sec., then the work done per second is equal to (W.V) foot-lbs., and the horse-power necessary to keep the body moving at this velocity is equal to $\frac{W.V}{550}$.

And suppose the B.H.P. of the motors installed in the machine to be denoted by (H), and the efficiency of the lifting screws to be (η), then the Effective Thrust Horse-Power of the motors is equal to (H. η), and this is the horse-power available for keeping the machine in motion.

So that we have

$$H.\eta = \frac{W.V}{550},$$

whence

$$V = \frac{550.\eta.H}{W} \text{ feet/sec.},$$

or

$$H = \frac{W.V}{550.\eta}.$$

Now suppose that $(V) = 0$, so that the machine remains stationary in the air, then

$$H = \frac{W}{550} \cdot \frac{0}{\eta} = \frac{0}{\eta},$$

and if (η) is not zero, the B.H.P. required to sustain the weight (W) vanishes.

But from the general expression for the efficiency of any type of air-screw, we notice that when the effective pitch, that is the advance per revolution of the air-screw, is zero the efficiency of the air-screw is also zero, so that (H) is not necessarily a vanishing quantity, for we obtain the expression

$$H = \frac{W}{550} \cdot \frac{0}{0} = \frac{0}{0},$$

which is indeterminate, and may be zero or a finite quantity.

We can however obtain the value of (H) for the case $(V) = 0$ from a consideration of the more general case when (V) is not zero.

And if, having obtained the value of (H) for finite values of (V) , we consider (V) and therefore the effective pitch to become very small and ultimately vanish, we shall obtain the required value of (H) for the case when the machine remains stationary in the air.

Suppose then that a body is moving vertically upwards with a uniform velocity of (V) feet/sec., under the action of screws which revolve at (n) revs./sec. Then the effective pitch of such screws will be $\frac{V}{n}$ feet, and if we know the diameter (d) of each screw we can find an expression for the efficiency of the screws in terms of the quantities already known.

We will suppose for the sake of simplicity that we are using a shape of air-screw blade similar to that already defined as the "Rational" blade. Then, if we further suppose that (c_y) and $(\tan \gamma)$ are constants over the blade, and that $(\tan \gamma)$ has the value of $\frac{1}{12}$, we can at once write down an expression

for the efficiency of the whole air-screw under the conditions specified.

The above assumptions are made for the sake of simplicity and convenience, and do not affect the general results to any very great extent. The "Rational" form of blade outline is such a simple one to deal with analytically that the great simplification in the work obtained by using this form of blade is a justification for not treating the problem of direct lift in its more general form, when the blade outline is considered as some arbitrary undetermined function of the radius (x).

The expression for the efficiency is therefore given by

$$\eta = \frac{2.Z.(8.\pi - Z)}{\pi.(8.\pi + 16.Z)}$$

and, since $(Z) = \frac{P}{d} = \frac{V}{n.d}$, we obtain

$$\eta = \frac{2.V.(8.\pi.n.d - V)}{\pi.n.d.(8.\pi.n.d + 16.V)}$$

And this expression is the value of the efficiency of the lifting screws under the conditions specified.

We are now in a position to estimate the necessary B.H.P. of the motors for the velocity (V) upwards. We have already shown that the required B.H.P. is given by

$$H = \frac{W}{550} \cdot \frac{V}{\eta}$$

and

$$\eta = \frac{2.V.(8.\pi.n.d - V)}{\pi.n.d.(8.\pi.n.d + 16.V)}$$

so that

$$H = \frac{W}{1100} \cdot \frac{\pi.n.d.(8.\pi.n.d + 16.V)}{(8.\pi.n.d - V)}$$

And now, if $(V) = 0$, then $(H) = \frac{W.\pi.n.d}{8800}$,

which gives the B.H.P. necessary for "hovering."

This was the case which before we were unable to evaluate owing to the indeterminateness of the expression $\frac{0}{0}$.

Thus as an example suppose that

$$\begin{aligned} W &= 1100 \text{ lbs.}, \\ n &= 20 \text{ revs./sec.}, \\ d &= 8 \text{ feet}, \end{aligned}$$

then the B.H.P. necessary to keep the machine hovering in the air is given by the value of (H), which in the above example is found to be equal to (63) B.H.P. approx.

It can be seen from the formula that when (V) is not zero, the B.H.P. required is greater than what it was for the case when (V) = (0), and as (V) increases so does (H) increase.

The value of (H) is strictly the value of the B.H.P. of the motors multiplied by the efficiency of the transmission to the lifting screws.

It will be noticed that when

$$(V) = 8.\pi.n.d$$

the value of (H) becomes infinite, which forms therefore the limiting value of (V). This limiting value of (V) is caused by the fact that when (V) has the value given above, (Z) is equal to (8. π), and this corresponds to a zero value of the efficiency of the air-screws.

Now in order that the screws may be capable of lifting the whole machine, it is necessary that their combined effective thrusts shall be greater than the total weight of the machine (W).

This is equivalent to saying that the air-screws must be capable of sustaining a greater weight than (W) when (V) = 0, for if it be supposed that the machine has an extra weight (w) attached to it, and that the screws are just supporting the combined weights of (W) and (w) in the air, then it is obvious that if the weight (w) be detached from the machine it will fall, and the machine will then be subjected to an accelerating force greater than its weight (W), and hence that it will commence to rise.

In order therefore that our helicopter may be capable of rising off the ground, the effective horse-power of the motors must satisfy the relation

$$H > \frac{W \cdot \pi \cdot n \cdot d}{8800}.$$

The quantitative determination of the acceleration produced by the reserve horse-power is somewhat difficult to arrive at.

There are however other considerations bearing upon the subject of vertical ascent in the air.

We have already shown that

$$H = \frac{W}{1100} \cdot \frac{\pi \cdot n \cdot d \cdot (\pi \cdot n \cdot d + 16 \cdot V)}{8 \cdot \pi \cdot n \cdot d - V},$$

whence

$$V = \frac{\pi \cdot n \cdot d \cdot (8800 \cdot H - W \cdot \pi \cdot n \cdot d)}{1100 \cdot H + 16 \cdot W \cdot \pi \cdot n \cdot d},$$

which gives the velocity of ascent through the air.

We notice at once that when

$$H = \frac{W \cdot \pi \cdot n \cdot d}{8800}$$

the value of (V) is zero, and the machine remains stationary. This is the condition already established for "hovering" flight.

In order, therefore, that (V) may be positive, it is necessary that

$$H > \frac{W \cdot \pi \cdot n \cdot d}{8800},$$

and this condition brings us to a consideration of the requisite values of (n) and (d), which values so far have been assumed to be anything whatever.

It is of course obvious that in order to obtain a good efficiency for the lifting screws, the value of (Z) should approximate to the value at which the efficiency of the screws is a maximum. But since it will be found that the velocity of ascent, and hence the effective pitch, may be small compared

to the diameter of the air-screw, unless this diameter be itself small, it will be more economical to use possibly a large number of separate air-screws, in which the ratio of effective pitch to diameter is such as to entail at least a moderately good efficiency. This may of course make the diameter of each individual air-screw quite small. The reason for using a number of separate air-screws is that the necessary width of blade would be inordinately large in the case of one or two lifting screws only, and hence the value of (c) would be such as to entail an enormous amount of interfering action between the blades of each air-screw.

Suppose then that there are (Q) separate air-screws, each exerting a thrust of $\frac{W}{Q}$ lbs., then the horse-power available for turning each screw is $\frac{H}{Q}$.

And let each air-screw (all of which are assumed to be identical) have (N) blades.

Then we have

Total thrust exerted by each air-screw = ($N.T$) lbs.,

and

Total weight required to be supported by each air-screw

$$= \frac{W}{Q} \text{ lbs.,}$$

whence

$$(N.T) = \frac{W}{Q}.$$

Now we have for simplicity assumed that the blade shape for each air-screw is that defined as the "Rational" blade shape. And we have further assumed that the section of the blade is uniform throughout the entire blade, except perhaps near the boss, which does not affect the argument to any appreciable extent.

We can then at once apply the formula already obtained for the thrust of an air-screw having this shape.

We have

$$N.T = \frac{c.n^2.\pi.\rho.c_y.P.d^2.(2.\pi.d - 3.P.\tan \gamma)}{12},$$

whence

$$\frac{W}{Q} = \frac{c.n.\pi.\rho.V.d^2.c_y.(2.\pi.d - 3.\frac{V}{n}.\tan \gamma)}{12},$$

and \therefore

$$Q = \frac{12.W}{c.\rho.\pi.V.d^2.c_y.(2.\pi.d.n - 3.V.\tan \gamma)}.$$

In this formula for the determination of (Q) all the factors are known with the exception of (V), the velocity of ascent.

We have, however, already obtained a formula for (V), viz.

$$V = \frac{\pi.n.d.(8800.H - W.\pi.n.d)}{1100.H + 16.W.\pi.n.d},$$

so that we can at once determine the least necessary value of (Q) for any chosen value of (c).

Suppose that

$$\begin{aligned} W &= 1000 \text{ lbs.}, \\ n &= 20 \text{ revs./sec.}, \\ d &= 10 \text{ feet}, \\ H &= 100 \text{ effective horse power}, \end{aligned}$$

and let

$$\begin{aligned} c &= \frac{1}{3}, \\ c_y &= .4, \\ \tan \gamma &= \frac{1}{12}, \end{aligned}$$

then, since we are using lb./ft./sec. units, (ρ) will have the value of (.00238), and hence we get the value of (Q) as given by

$$Q = \frac{12 \times 1000}{\frac{1}{3} \times .00238 \times \pi \times 15 \times 10^2 \times .4 \left(2.\pi.10.20 - \frac{15}{4} \right)} = 6.$$

We thus obtain the least value of (Q) required in order that the initial conditions may be satisfied.

We notice that if (c) be less than $\frac{1}{3}$, the necessary value of (Q) will be greater than (6).

If we solve formally to obtain (Q) in terms of (H), we get

$$Q = \frac{48. (1100.H + 16.W.\pi.n.d)^2}{129.c.\rho.\pi^4.d^5.c_y.n^3. (8800.H - W.\pi.n.d)}$$

and it can be seen from this that as (d) decreases in value (Q) increases. It is interesting to consider for what value of (d) (V) has a maximum value, and hence to obtain the necessary value of (Q) for this.

To find the value of (d) for which (V) is a maximum, we put

$$\frac{dV}{dd} = 0,$$

and this gives

$$d = \frac{(712 \cdot 5).H}{W.\pi.n} = \frac{227.H}{W.n}$$

as the value giving (V) a maximum value.

To obtain the value of the maximum value of (V), we substitute the value of (d) obtained from the above in the general formula for (V), and get

$$V_{\max} = \frac{462.H}{W} \text{ feet/sec.},$$

and this gives the maximum velocity upwards under the best possible conditions.

The value of the number (462) depends upon the value of ($\tan \gamma$) taken.

We also notice that the efficiency of the lifting screws under these conditions is equal to $\frac{462}{550}$, that is approximately (84) per cent.

Thus a machine, weighing complete with engines, screws

fuel, etc., (1000) lbs., and having motors capable of developing an effective horse-power of (100), would have an upward velocity under the best conditions as already given of (46·2) feet per second, or roughly (2800) feet per minute. This rate of climbing is about double that of the fastest aeroplane scouts at present in existence.

We can now obtain the necessary value of (Q) for a maximum value of (V).

We get

$$Q = \frac{(\cdot 391)(10^{-10}) \cdot W^5 \cdot \pi \cdot n^2}{c \cdot \rho \cdot c_y \cdot H^4},$$

and since

$$d = \frac{227 \cdot H}{W \cdot n} \text{ for a maximum value of (V),}$$

where (n) is arbitrary, we can find the necessary value of (Q) for any arbitrary chosen value of (d).

This then gives

$$Q = \frac{(\cdot 199)(10^{-4}) \cdot W^3}{c \cdot \rho \cdot c_y \cdot H^2 \cdot \pi \cdot d^2},$$

whence the larger the value of (d) the smaller the value of (Q).

Applying this result to the previous example, where

$$W = 1000 \text{ lbs.,}$$

$$c = \frac{1}{3},$$

$$c_y = \cdot 3,$$

$$H = 100,$$

$$d = 10 \text{ feet,}$$

we get

$$Q = 26 \cdot 2.$$

So that we shall require at least (27) separate helices in order that (c) may have a value not greater than $\frac{1}{3}$.

Thus the blades would have to be between two and three

feet wide and the air-screw would have to rotate at a speed given by the relation

$$n = \frac{227.H}{W.d},$$

so that

$$(n) = 2 \cdot 27, \text{ which is approximately } (136) \text{ revs./min.}$$

It is a simple matter to determine the necessary value of the blade widths at any radius (x) along the blade. We have

$$b = \frac{2.c.P.\pi.x}{N.\sqrt{P^2 + 4.\pi^2.x^2}},$$

giving the value of (b) for any radius (x).

At the tip of the blade (x) = (r), and the value of (b) is then given by

$$b_r = \frac{c.P.\pi.d}{N.\sqrt{P^2 + \pi^2.d^2}}.$$

Applying this last result to the example given above we get

$$b_r = \frac{1}{3} \times \frac{46 \cdot 2}{2 \cdot 27} \times \pi \times 10 \\ = \frac{5 \cdot 3}{N} \text{ feet (approx.).}$$

So that if $N = 2$, that is, if each air-screw has (2) blades we get

$$b_r = (2 \cdot 65) \text{ feet (approx.),}$$

and this is the necessary value of the blade width at the tip under the conditions specified.

As stated in the Preface the results given by the theory in the case of Direct Lifting Systems and for Static Thrust must not be accepted without due caution.

Owing to the fact that in both these cases the translational velocity of the machine is usually zero or very small, and hence the ratio of the slip-stream velocity to this velocity rather high, the angles of attack of the various blade elements

are not the same as given by the theory, and consequently the results obtained from it by calculation may be quite fallacious.

It would appear, however, that, providing the value of (Z) is sufficiently large and in the neighbourhood of that obtaining in standard types of air-screws as used upon aeroplanes (that is having a value of say between .4 and unity), the results as given by the theory in Chap. IX. should be found to be sufficiently true, at any rate as a basis for practical design and further investigation.

This would probably necessitate a very high rate of ascent, or at any rate the utilization of the value of (Q) giving a maximum value to (V), in order to obtain the requisitely large value for (Z).

The calculated value of the B.H.P. required for "hovering," given on page 112, is for these reasons probably much too small.

Mr. F. W. Lanchester, in a recent paper,* gives a formula for the determination of the least requisite B.H.P. for a stationary helicopter, his expression being

$$\frac{W}{h.p.} = 550 \sqrt{\frac{2.A.\rho}{32 \cdot 2 \cdot W}}$$

where (A) is the area of the propeller disc, (W) is the weight sustained, and (ρ) the density of the fluid, in the case of air approx. $\frac{1}{13}$, or 0.078.

If we apply this to the example quoted, we obtain (135) as a minimum value for (H). This is probably a much more accurate figure.

* "The Screw Propeller," by F. W. Lanchester, M.Inst.C.E., read before the Institution of Automobile Engineers in April 1915.

APPENDIX I

NOTE ON THE INFLUENCE OF "ASPECT RATIO."

IN the Introduction a brief reference was made to the ratio of the span to the chord of a wing, commonly known as the "Aspect Ratio." It is fairly certain that the characteristics of an aerofoil vary with variation of aspect ratio, although any exact quantitative determination of the alteration of lift and $\frac{\text{lift}}{\text{drag}}$, corresponding to a given change in the value of the aspect ratio of a wing, would appear to be impossible at present.

At the same time it would appear that an increase in the value of the $\frac{\text{lift}}{\text{drag}}$ always accompanies an increase in aspect ratio.

The graph given in Fig. 46 is plotted from the result of tests on a wing carried out at the National Physical Laboratory,* and serves as an indication of the kind of change to be expected. The difficulty of correctly anticipating the amount of this change in any case appears to be largely due to the form of the wing tips employed.

This question of aspect ratio should be taken into account as far as possible when designing an air-screw, as experimental tests have shown that high efficiencies may usually be expected from screws having blades of a high aspect ratio.

In fact it is apparent that, without attempting to formulate any exact connection between blade efficiency and aspect ratio, a high speed air-screw might conceivably have a better efficiency owing to the necessary comparative narrowness of

* "Technical Report of the Advisory Committee for Aeronautics, 1911-12."

the blades than one designed for the same conditions but to rotate at a slower and otherwise more economical speed.

It is obvious, therefore, that this question cannot be altogether neglected either in aeroplane or air-screw design, and, in view of the comparatively meagre information at present available on the subject, further experimental research in this direction would appear to be required.

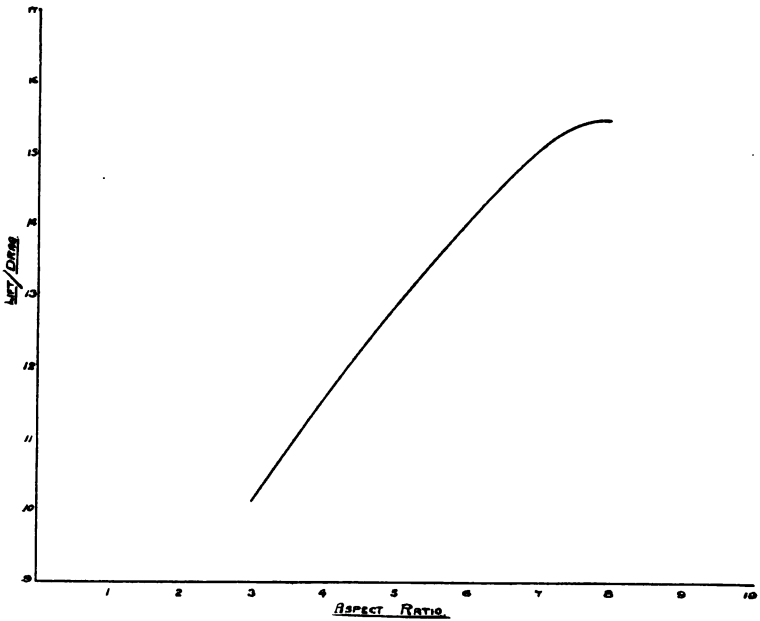

FIG. 46.

APPENDIX II

NOTE ON THE EFFECT OF THE INDRAUGHT IN FRONT OF AN AIR-SCREW.

IT was stated in the Preface that the theory here outlined was not in any sense to be regarded as bearing any more than a fairly close relationship to the actual conditions surrounding the working of a screw in air. It would indeed be well nigh an impossibility to formulate a theory which would adequately deal with *all* the various complex factors entering into the problem of screw propulsion in fluids, and the most that scientific analysis can do is to build up some kind of a working hypothesis which may reasonably be expected to give results sufficiently true for the purpose of practical design.

In fact, in any investigation of this kind, certain factors bearing upon the problem may have to be ignored owing to the difficulty of accurately representing their effects without the too continuous employment of experimental data in the form of checks upon the theory.

One such factor, of which no quantitative notice has been taken in the previous work, is the indraught of air in front of an airscrew, the effect of which is to modify the conditions under which any element of blade has been assumed to be working. The main modifications introduced by such an indraught appear to be a decrease in the "angle of attack" and an increase in the relative air velocity of each element along the blade, thus altering to some extent the values of the air reactions upon the same, although it is evident that these two effects tend to partially neutralise each other. Quantitatively, however, it appears to be very difficult to readjust the foregoing theory so as to include this effect of indraught, without very much greater experimental evidence than is at the present time available. Some experiments have been carried out by G. Eiffel* to determine the magnitude of this incoming air, and he shews that the ratio of the indraught velocity to the velocity of translation is a function of the $\frac{\text{pitch}}{\text{diameter}}$ ratio only.

* "Nouvelles Recherches sur la Résistance de l'Air et l'Aviation," 1914.

If we assume that the analogy with aerofoils still holds for every element of the blade, it is a simple matter to shew that this ratio cannot exceed a certain limit directly depending upon the value of the "angle of no lift" for the blade section considered. The value of this ratio for air-screws of the type as at present employed, and having $\frac{\text{pitch}}{\text{diameter}}$ ratios of from ($\cdot 5$) to ($\cdot 7$), appears to lie in the neighbourhood of ($\cdot 6$) to ($\cdot 7$) for the effective portion of the blade.

Further, if we assume that the correction factor already given for the calculated torque of a blade to be capable of being applied to each element along the blade between the limits of integration, we obtain a value of about ($\cdot 4$) for this ratio as sufficient to account for the difference between the values of the torque as calculated and found by experiment.

The value of the correction factor taken is $\left(\frac{100}{75}\right)$.

For a value of ($\cdot 4$) for this ratio, the "angles of attack" of the elements near the blade tip are found to be between (3°) and (4°) less than the original values assigned to them when no account was taken of the indraught. This would make the real values of these angles of attack nearly zero for blades designed on the aerofoil theory.

Eiffel's experiments do not, however, appear to substantiate this view, the values of this ratio for various speeds of translation appearing not to exceed ($\cdot 1$). In any case, without further experimental evidence it is quite useless to attempt to fix any definite value for this ratio.

This question of the ratio of the indraught velocity to the translational velocity is one which becomes of fundamental importance in the case of screws having very small or zero values of the effective pitch to diameter ratios, and were it possible to obtain an accurate determination of the amount of this ratio in such cases, the problem of the helicopter already discussed would be much easier of a representative solution than has so far been found to be the case, owing to the limitations of the present theory.

INDEX

- "Aerial Flight," 3
 Aerodynamical efficiency,
 48
 Aerofoil, 1
 Aeronautical Society, 40
 "Aeroplane," 90
 Air-flow, 1
 Air pressure, 16
 "Air-screws," Paper on, 40
 "Angles of attack," 13, 56
 Angles of incidence, 13
 "Aspect Ratio," 3, 121
 "Average" reaction, 11, 21
 Bending moment, 81, 82
 Bent plane, 1
 B.H.P., 18, 52, 59, 119
 Biplane, analogy of, 30
 Blade elements, 13
 Blade sections, 14, 47
 Blade shape, 25
 Blade tip angle, 10
 Blade width constant, 59
 Bolas, H., 65
 Bramwell, F. H., 4, 12, 90
 Bryan, G. H., 1
 (c), value of, for normal
 incidence, 3
 Calculus of Variations, 55
 Camber, 48
 Centre of area of sections,
 72
 Centre of pressure of sec-
 tions, 72
 Centrifugal forces, 5, 77
 Centrifugal pull, 77
 Chord angles, 10, 13
 "Constant Pitch," 10
 "Constructional Limit"
 type of blade, 35
 Contours, plotting of, 76
 Convex under-surface, 76
 Correction factor on blade
 width, 63
 Cylinder, 7

- Diameter of air-screw, 51
 Direct lifting systems, 109, 118
 Dirigible, 91
 Discontinuous blade outline curve, 44
 Discontinuous fluid motion, 1
 Drag, 2
 Drag coefficient, absolute, 2
 Drzewiecki, iii, 3, 4
 "Effective Pitch," 9, 10
 Efficiency curve, 27
 "Efficiency curve" blade shape, 29, 35
 Efficiency, maximum point of, 27
 Efficiency of an air-screw, 19, 91
 Efficiency of an element, 26
 Eiffel, G., 123
 Elliptical shaped ends, 55
 Empirical multiplying factor, 63
 Equations, 17
 Experimental Mean Pitch, 12, 19, 21
 Experimental research, 51
 Fage, A., 4, 90
 Flat plate, 1
 Fluid motion, discontinuous, 1
 Formula for air-pressure, 1
 Formulæ, working, 47
 Fundamental hypothesis, 3
 "Gap," 31
 "Gap/chord" ratio, 31
 Gliding angle, 3, 14
 Graphical methods, iv, 60, 93
 Helicoidal path, 6
 Helicopter, 113, 119
 Helix, 7, 8
 Helix, angle of, 9
 Helix angles, 13
 Helix, length of, 8
 Hovering flight, 113, 119
 Ideal thrust grading diagram, 43
 Indraught in front of an air-screw, 123
 Infinitesimals, 23
 Integration, 15
 Interference, 30
 Jones, R., 1
 Laminæ, 34, 73
 Lanchester, F. W., 3, 4, 119

- Laying out blade, 72
 Lift coefficient, absolute, 2
 Lift/drag ratio, 2
 Lift of an aerofoil, 2
 "Load Grading Curve," 23
 Low, A. R., 34, 38, 40
- Marine propellers, 4
 Marine work, iii
 Mathematical theory, 1
 Mathematics, iv
 "Maximum maximorum,"
 82, 85
 Maximum ordinate, position of, 27, 30
 Moment of inertia, 81
- National Physical Laboratory, 4, 90
 Negative pressure, 2
 Neutral axis, 80
 "Normale" blade shape,
 34, 35
- Outside fibres, 81
- Pitch of an air-screw, 6
 Pitch of zero "average"
 Reaction, 11
 Pitch of zero Thrust, 11
 Pitch of zero Torque, 11
 Pitch ratio, 40
- Pressure, negative, 2
 Pressure, positive, 2
- "Rational" blade efficiency
 formula, 40
 "Rational" blade shape,
 34, 35
- Resultant air pressure, 1,
 14, 21, 22
 Resultant Thrust, 11
 Resultant Torque, 11
 Royal Society, Proceedings
 of, 1
- Screws, marine, 4
 Slip-stream, 43
 Slip-stream velocity, 119
 Speeding up of air, 86
 Static Thrust, 86, 118
 Stresses, 47
 Stresses, bending, 80
 Stresses, centrifugal, 77
 Symmetrical plan form, 72
- "Technical Report of the
 Advisory Committee for
 Aeronautics, 1911-12,"
 49, 65
 "Technical Report of the
 Advisory Committee for
 Aeronautics, 1912-13,"
 4, 69

- "The Screw Propeller," 119
 Thickness/chord ratio, 47,
 56
 Thrust of a blade, 18, 19
 Thrust of an element, 16
 Thrust, Static, 86
 Torque of a blade, 18
 Torque of an element, 17
 Translational velocity, 9,
 118

 Velocity, climbing, 91
 Velocity, maximum, 91
- Velocity, minimum, 91
 Velocity of blade element,
 16
 Vertical ascent, 113

 Walnut, safe working load
 of, 85
 "Wash" of top wing,
 30
 Whitehead, A. N., iv
 Wind-tunnel, 19
 Working formulæ, 47
 Wright Aeroplane, 65 **B**

GENERAL LIBRARY
UNIVERSITY OF CALIFORNIA—BERKELEY

RETURN TO DESK FROM WHICH BORROWED

This book is due on the last date stamped below, or on the date to which renewed.

Renewed books are subject to immediate recall.

27 Oct '54 MD

OCT 27 1954 LU

24 May '62 P

REC'D LD

MAY 31 1962

28 May '65 SW

REC'D LD

MAY 17 '65 -11 AM

21-100m-1,'54(1887s16)476

